

SPANAWAY WATER COMPANY

STANDARD CONSTRUCTION SPECIFICATIONS

VALID THROUGH DECEMBER 31, 2026



Table of Contents

<u>OBJECTIVE, GENERAL REQUIREMENTS, GENERAL NOTES</u>	3
<u>PIPE AND FITTINGS</u>	5
Class 52 Ductile Iron Pipe	
Pipe Fittings	
Casing Pipe	
Transition, Reducing, and Flexible Couplings	
Handling of Pipe, Fittings, and Appurtenances	
Installation of Pipe and Fittings	
Tracing Wire	
Buried Caution Tape	
Connection to Existing Water Mains	
Concrete Blocking	
<u>TRENCH EXCAVATION, FOUNDATION, BEDDING AND BACKFILL</u>	8
Bank Run Gravel for Trench Backfill	
Trench Excavation	
Asbestos Cement (AC) Pipe	
Asbestos Cement (AC) Pipe – Removal, Packaging, Transport, and Disposal	
Undermining Of Asbestos Cement Water Main	
Bedding	
Backfilling Trenches	
<u>VALVES</u>	9
Resilient Seat Gate Valves	
Butterfly Valves	
Valve Boxes	
Tapping Sleeve and Tapping Valves	
Combination Air Release/Air Vacuum Valves	
Sample Stations	
Pump and Pressure Reducing Stations	
Valve Marker Posts	
<u>HYDRANTS</u>	11
Fire Hydrants	
Blow Off Assembly	
<u>SERVICE CONNECTIONS</u>	12
Service Lines	
Conduit Pipe	
Setters, Meters, and Boxes	
Abandoned Services	

INSPECTION, DISINFECTION, AND TESTING 13

- Construction Staking
- Construction Inspection
- Non-Water Construction Inspection
- Disinfection of Water Mains
- Flushing of Water Mains
- Water Quality Tests
- Hydrostatic Pressure Test
- Testing Extensions from Existing Mains
- Fire Flow Test
- Typical Testing Sequence

EROSION CONTROL 18

RESTORATION AND CLEANUP 19

AS-BUILT INFORMATION 19

GUARANTEE AND WARRANTY 20

STANDARD DETAIL DRAWINGS 21

- 1 – Water Main Trench Section
- 2 – Fire Hydrant Assembly
- 3 – Fire Hydrant Located In Cut or Fill
- 4 – Fire Hydrant Bollards
- 5 – Hot Tap Connection
- 6 – Cut In Connection
- 7 – Undermined AC Water Mains
- 8 – End Line Blow Off Assembly
- 9 – Combination Air and Vacuum Relief Assembly
- 10 – Water Service Connection (5/8"x3/4")
- 11 – Water Service Connection (1")
- 12 – Water Service Connection (1-1/2")
- 13 – Water Service Connection (2")
- 14 – Valve Box
- 15 – Valve Extension Stem
- 16 – Vertical Anchor Block
- 17 – Thrust Blocks
- 18 – Typical Utility Crossing (Storm)
- 19 – Typical Utility Crossing (Sewer)
- 20 – Clearances for Typical Water Services
- 21 – Typical Road Cross-Section
- 22 – Typical Reduced Pressure Backflow Assembly (RPBA and RPDA)
- 23 – Sample Station Typical Installation
- Construction Water Use Agreement - Water Truck Authorization form
- Construction Water Use Agreement – On-Site Fire Hydrant Meter Use Authorization form
- Sand Bedding Box Use Agreement – Sand Bedding Box Rental Form

OBJECTIVE

This document and attached standard details are intended to present information and provide an outline of minimum general construction standards. These standards are required by Spanaway Water Company (SWC) for Developer constructed water main extensions and improvements that are to be acquired and operated by SWC.

SWC does not assume responsibility for the notification of updated documents or policy. The Company should be consulted in case of doubt on the applicability of any item(s) within. Some of the information contained within is based on governmental codes and ordinances and industry standards that are subject to change in the event that such governing codes and ordinances are changed.

GENERAL REQUIREMENTS

Except as otherwise noted, all work and materials shall conform to the current Standard Specifications for Municipal Public Works Construction prepared by the Washington State Chapter of the American Public Works Association, and current amendments thereto. Or as revised to make reference to Local Governments and as modified by the Company's requirements and standards. **Unless otherwise pre-approved by SWC, all materials shall be manufactured within the United States. All brass fittings shall meet the new "lead free" standards as defined under Public Law 111-380, the "Reduction of Lead in Drinking Water Act".** The same manufacturer of each item shall be used throughout the work.

SWC staff and their designated engineer shall develop water system design drawings. The drawings will provide the locations, size, and type of the proposed water system main lines, fittings, appurtenances, and points of connection. The water design will be based on the site plan and civil engineering drawings as provided by the developer's engineering consultant. The installation of all water mains and appurtenances as well as the location of all fire hydrants will require review and approval by the Pierce County Fire Prevention Bureau prior to construction.

Except as otherwise noted herein, all work shall be accomplished as recommended in applicable American Water Works Association (AWWA) Standards, and according to the recommendations of the manufacturer of the material or equipment concerned.

The location of the water mains, valves, hydrants, and principal fittings including modifications shall be staked by the Developer. No deviation shall be made from the required line or grade. The Contractor shall verify and protect all underground and surface utilities encountered during the progress of this work. All installation, inspection, testing and restoration shall be completed prior to final acceptance and commencement of water service.

Pierce County Public Works shall be notified in advance of the date and time that implementation is to be made for all detours, closures, and other activities involving the disruption of travel of pedestrian or vehicular traffic. Notice shall be in compliance with the project's right-of-way permit from Pierce County and the most current "Manual on Accommodating Utilities in Pierce County Rights-of-Way". The Contractor shall be responsible for and maintain during all phases of construction, the access for safe vehicular traffic, pedestrian traffic, and emergency vehicles. The posting of flagmen, advance warning signs, barricades, traffic cones, flashers, etc., shall be the responsibility of the Contractor and shall be in accordance with the current "Manual on Uniform Traffic Control Devices for Streets and Highways" as accepted by the Washington State Department of Transportation. Whenever, in the opinion of the SWC Inspector or Pierce County Public Works, traffic conditions dictate, a uniformed officer shall be employed to control traffic until the Inspector determines that there no longer exists any traffic problem.

GENERAL NOTES

1. All work and materials shall be in complete accordance with the standards and conditions of SWC, Washington State Department of Health, the American Public Works Association, the American Water Works Association, and the project specific water design drawings. All construction materials to be

- used in the project shall be specifically identified by written submission to SWC for review and approval prior to construction. Any items not explicitly approved by SWC shall not be used.
2. The Contractor shall notify SWC a minimum of two weeks prior to any water main construction to schedule a pre-construction meeting and allow SWC to coordinate a right-of-way permit with Pierce County Department of Public Works and Utilities.
 3. Contractor shall provide SWC with a written construction schedule a minimum of five working days prior to the start of work. The Developer/Contractor shall abide by the Company's normal working schedule including holidays. The intent of this schedule is to show the work done within the past week and to show the work planned for the next 2 weeks. The schedule should include the major work to be performed and the contractor responsible for that work. The 3-Week Look-Ahead Schedule is not a contract document and shall be provided in a bar chart format showing the major work items for each day of the schedule.
 4. Contractor shall notify SWC a minimum of 48 hours in advance to have SWC personnel shut-off or turn-on any water valve on the water system.
 5. Contractor shall "Call Before You Dig" (1-800-424-5555) prior to construction to locate any existing underground utilities. Contractor shall investigate and locate all buried utilities or obstructions in the construction area prior to construction of the water main extension. Contractor shall coordinate with SWC, Pierce County Public Utilities Department (sanitary sewer), Gas Company, Telephone Company, Power Company, and all other affected utilities for field location of the respective existing facilities.
 6. Water mains shall be installed only in public right-of-way or in private road or utility easements that have been or will be dedicated to the Company. Permanent easements of not less than twenty feet (ten feet on each side of the centerline of the water main) shall be provided.
 7. All water mains shall maintain 36 inches (minimum) to 42 inches of cover unless otherwise specified on the project design drawings.
 8. Horizontal and vertical separation between water and sanitary sewer mains and sewer laterals shall be per Pierce County Public Works and Utilities Department requirements. Maintain a minimum horizontal separation of 10 feet between potable water lines and any existing or new sanitary sewers and/or reclaimed water lines. The distance shall be measured edge to edge (i.e., from the outer diameter of the pipes.) The standard minimum vertical separation for water lines is 1.5 feet above the sewer line (separation shall be measured from the outer wall of the pipes). If standard clearances cannot be obtained, then either the sanitary sewer shall be concrete encased or class 52 ductile iron pipe shall be used for the sewer main. Concrete encasement and ductile iron pipe substitution of sewer mains will be allowed for water mains crossing at less than 1.5 feet but no closer than .75 feet. Water lines shall not be encased.
 9. Minor items of work or materials omitted from Plans and Specifications prepared by the Company, Company's Engineer, or Developer's Engineer, but clearly inferable from the same and which are called for by accepted good practice, shall be provided and/or performed by the Developer as part of the construction. In case of doubt, the Company shall be consulted and its decision shall be determinative.
 10. The Contractor shall be responsible to ensure that all construction methods and procedures will be performed in accordance with Washington Industrial Safety and Health Administration (WISHA) and the Occupational Safety and Health Administration (OSHA) Safety Standards.
 11. All construction water tank trucks (road cleaning, dust control, compaction, hydroseeding, etc.) shall be filled from the designated connection located at the SWC main office. Water from tank trucks is non-potable and is therefore forbidden from use in or around water infrastructure. This includes pressure testing, cleaning water pipe, and AC dust suppression. All tanks or vessels shall have approved cross connection control, preferably an approved air gap. Cross connection control must be approved by SWC personnel. All Contractor vehicles must be inspected, or show SWC approval based on earlier inspection prior to any filling. On-site construction water via a hydrant meter will only be allowed under special arrangement and contract with SWC. Refer to SWC 'Construction Water Use Agreement'. A signed copy of that agreement shall be kept in the inspected vehicle at all times, to be made available to SWC personnel upon request.

PIPE AND FITTINGS

Class 52 Ductile Iron Pipe

Water mains shall be cement-lined Class 52 ductile iron water pipe, conforming to the most recent AWWA standards C104 (Cement-Mortar Lining), C111 (Rubber-Gasket Joints), C150 (Thickness), and C151 (Ductile Iron Pipe) except as directed by the Company or specifically noted on the approved design drawings or standard details. Grade of iron shall be a minimum of 60-42-10. The pipe shall be cement lined to a minimum thickness of 1/16" AWWA C-104 and the exterior shall be coated with an asphaltic coating. Each length shall be plainly marked with the manufacturer's identification, year case, thickness, class of pipe and weight. All materials shall be new and undamaged.

Pipe Fittings

All fittings shall be cement-lined ductile iron conforming to the most recent AWWA standards C153, C110, C115, C104, and C111. Fittings shall be constructed to accommodate the pipe being used. Joints shall be mechanical joint or push-on type, employing a single gasket, such as "Tyton Joint", except where otherwise calling for flanged ends. Bolts furnished for mechanical joint pipe and fittings shall be high strength ductile iron, with a minimum tensile strength of 50,000 psi.

Restrained joint pipe, where shown on the Plans shall be push-on joint pipe with gaskets. Restrained joint pipe shall meet all other requirements of the non-restrained pipe.

All pipe shall be jointed by the manufacturer's standard coupling, be all of one manufacturer, and carefully installed in complete compliance with the manufacturer's recommendations.

Joints shall be fabricated in accordance with the manufacturer's recommendations. Standard joint materials, including rubber ring gaskets, shall be furnished with the pipe. Material shall be suitable for the specified pipe size and pressures.

All fittings shall be short-bodied, ductile iron meeting the 350 psi pressure rating for mechanical joint fittings and 250 psi pressure rating for flanged fittings. All fittings shall be cement lined and either mechanical joint or flanged, as indicated on the design drawings.

Fittings in areas shown on the Design Drawings for restrained joints shall be mechanical joint fittings with a mechanical joint restraint device. The mechanical joint restraint device shall have a working pressure of at least 250 psi with a minimum safety factor of 2:1 and shall be "EBAA Iron, Inc., MEGALUG", or Romac brand "RomaGrip™" pipe restraint systems, or approved equal. All mechanical joint fittings shall be restrained.

Casing Pipe

Steel Casing Pipe shall be ASTM Designation A-53 or comparable, minimum 3/8" wall thickness for 20" casing pipe. Install casing by boring with approved equipment. Weld joints for water tightness. Construct bore pit and conduct bore related activities in accordance with local jurisdiction requirements.

Transition, Reducing, and Flexible Couplings

All ductile iron pipe couplings shall be push-on mechanical joint sleeves. Transition couplings shall be 'Romac' brand, or equal as approved by SWC.

Handling of Pipe, Fittings and Appurtenances

Pipe, fittings and appurtenances shall be handled in such a manner as to ensure delivery to the site and final installation in sound, undamaged condition. Particular care shall be taken not to injure the coating and lining and to keep the pipe clean. These items shall be loaded and unloaded using hoists in a manner so as to avoid shock or damage, and under no circumstances shall they be dropped or skidded or rolled against other pipe. If any part of the coating is damaged, repairs shall be made by the Contractor at his expense and in a manner satisfactory to the Company. If any part of the lining is damaged, the pipe shall be rejected. Damaged pipe will be rejected at the discretion of the SWC. The Contractor shall immediately place all damaged pipe apart from the undamaged and shall remove the damaged pipe from the site within 24 hours.

The pipe and fittings shall be inspected for defects before installation. All lumps, blisters and excess coal tar coating shall be removed from the bell and spigot end of each pipe. The outside of the spigot and the inside of the bell shall be wire-brushed and/or wiped clean and dry, and shall be free from oil and grease before the pipe is laid.

The Contractor will not be permitted to string more pipe than can be installed in one day along streets and roads. No more pipe than can be installed in one day shall be hauled to the site of the work.

Installation of Pipe and Fittings

Pipe shall be installed in accordance with the pipe manufacturer's printed specifications and instructions and these specifications. All pipe shall be laid to the designed lines and grades to provide the required cover and/or slope as shown on the Design Drawings. The slope of a main line need not be constant, but shall be such that no high or low points exist in the finished line except as shown on the Design Drawings. The amount of deflection at each pipe joint when pipe is laid on horizontal or vertical curves shall not exceed the manufacturers recommended deflections.

Every precaution shall be taken to prevent foreign material from entering the pipe while it is being placed in the trench. Dirt or other foreign material shall be prevented from entering the pipe or pipe joint during handling or laying operations. Any pipe or fitting that has been installed with dirt or foreign material in it shall be removed, cleaned and re-installed.

All parts of the pipe ends, couplings, fittings, and appurtenances shall be cleaned to remove oil, grit, or other foreign matter from the joint. Care shall be taken to keep the joint from contacting the ground. At times when pipe installation is not in progress, the open ends of pipe shall be closed by a watertight plug. If water is in the trench when work resumes, the seal shall remain in place until the trench is pumped completely dry. No pipe shall be laid in water or when trench conditions are deemed unsuitable.

Pipe shall be cut with tools recommended by the manufacturer and shall be smooth, even and square. All chips and cuttings shall be removed from the interior of the pipe. All pipe ends shall be reamed and otherwise smoothed or beveled to prevent damage to gaskets and to make good connections. Cutting of ductile iron pipe with oxyacetylene torch is not allowed. All cutting and pipe preparation procedures shall meet most current safety methods.

Pipe shall be laid with bell ends facing in the direction of the laying, unless directed otherwise by the Company. Provide bends in field to suit construction and in accordance with pipe manufacturer's recommendations. Wherever it is necessary to deflect pipe from a straight line, the amount of deflection allowed shall not exceed pipe manufacturer's recommendations. When rubber gasket pipe is laid on a curve, the pipe shall be jointed in the straight alignment and then deflected to the curved alignment. Trenches shall be made wider on curves for this purpose.

For connection of mechanical joints, the socket, plain end of each pipe and gasket shall be cleaned of dirt before jointing, and shall be jointed according to manufacturer's directions. Bolts shall be tightened alternately so pressure on the gasket is evenly applied.

For connection of "Tyton" type joints, the jointing shall be done according to manufacturer's recommendations, with special care used in cleaning the gasket seat to prevent any dirt or sand from getting between the gasket and pipe. Lubricant to be used on the gasket shall be non-toxic and free from contamination. Pipe not furnished with a depth mark shall be marked before assembly to ensure visual observation of the work.

All of the new piping, valves and blocking shall have been installed, disinfected and tested up to the point of cutting into existing lines before the crossover is made. The crossover to the existing system shall be in full readiness, including the cut and sized pipe sections. Forty-eight (48) hour notice shall be given to the Company in advance of the planned "cut-ins".

Tracing Wire

Use blue plastic coated 14 gauge (minimum) copper tracing wire. Tracing wire shall be installed on all water main and service lines. The tracing wire shall be placed directly on the top of the water line and wrapped once around each pipe length. The wire shall be continuous over the main lines full length. The wire

shall be looped to the finished grade in every valve box and blow-off vault, and run to the setter assembly of each service line. All wire splices shall be '3M' brand 'Direct Bury Splice Kit 09964' or approved equal. The wire shall be spliced to wire on existing mains when available. The continuity of the installed locate wire (mains and services) will be tested as part of the final system acceptance.

Buried Caution Tape

Use 2-inch metallic 5 mil (minimum) buried caution tape. Caution tape shall be blue with black lettering (BURIED WATER LINE BELOW) installed above all water main and service lines. The caution tape shall be placed directly over the top of the water line approximately 18" above the line unless an alternate position is specified in the design drawings.

Connection to Existing Water Mains

The type of connection to be made to existing mains will be determined by SWC and the design Engineer and shown on the design drawings. The connection schedule and timing will be the decision of the SWC. Connections may be made to existing pipe under pressure with tapping machine by determining the size and type of pipe and installing appropriate tapping sleeve and valve. Where permitted, cut-ins on existing pipes shall be conducted at such time and in such a manner as to minimize the interruption of service. Schedule for cut-in must be approved by the Company. Necessary pipe, fittings and valves shall be assembled at the site ready for installation prior to the shutting-off of water in the existing main. Once the water has been shut off, the work shall be prosecuted vigorously, and shall not be halted until the line is restored to service. The tapping sleeves shall be stainless steel, furnished complete with joint accessories. Tapping sleeves shall be constructed in two sections for ease of installation and shall be assembled around the main without interrupting service.

The Contractor shall verify the locations and establish the depth of the existing water mains at the points where connections are to be made prior to trenching for the main lines. The profile shall be adjusted so neither a "high" spot nor a "low" spot is created adjacent to the connection to the existing water mains.

Concrete Blocking

Provide thrust blocking and restraining joints at all fittings and bends. Concrete blocking shall be pre-cast 'ecology blocks' with a rebar, cable, or wire picking point or approved equal. Blocking shall bear against the fitting only. All bends and tees shall be blocked in accordance with the Standard Thrust Block Detail.

The use of ½ ecology block (2'x2'x3' – Corliss #10001350 or approved equal) is required for the installation of blow-off assemblies installed on 8-inch or smaller main lines and the blocking on fire hydrant risers (when specified), see the Standard Detail Drawings. One-half blocks may be used for all pipe run fittings and bends of 12-inch diameter and smaller, see Thrust Block Standard Detail.

The use of full ecology block (2'x2"x6' – Corliss #10004350 or approved equal) shall be used for the installation of blow-off assemblies installed on 12-inch mains and all pipe run fittings and bends of 16-inch or greater, or as determined by SWC's consulting engineer. The blocks must be set on level ground, butting against the affected fitting, with backfill compacted between the back of block and undisturbed soil. **Thrust blocking requirements may be altered based on water main design and field conditions and will be determined by SWC's consulting engineer.**

Vertical thrust blocking shall typically be per the SWC 'Vertical Anchor Block' detail. The application of alternative methods and materials shall be determined by SWC's designated consulting engineer on a case by case basis. All thrust blocks shall be left open for inspection and shall not be backfilled prior to Company inspection and specific approval.

TRENCH EXCAVATION, FOUNDATION, BEDDING AND BACKFILL

Bank Run Gravel for Trench Backfill

Where required, Trench Backfill Material shall consist of Bank Run Gravel Class A or Class B, as specified in Section 7-10 of the Standard Specifications excepting, however, that 100 percent of the material shall pass the 3-inch square opening.

Trench Excavation

The clearing and grubbing, where required, shall be performed within the easement or public right-of-way and as permitted by the property owner or governing agencies. Debris resulting from the clearing and grubbing shall be disposed of by the Contractor.

Trenches shall be excavated to provide 36-inches to 42-inches of cover over the pipe, unless otherwise shown on the Design Drawings. Except for unusual circumstances the trench sizes shall be excavated vertically and the trench width shall be excavated only to such width as necessary for adequate working space. The trench shall be kept free from water until jointing is complete. Surface water shall be diverted so as not to enter the trench.

All necessary shoring operations will be performed to ensure that the excavation can be carried out accordance with Washington Industrial Safety and Health Administration (WISHA) and the Occupational Safety and Health Administration (OSHA) Safety Standards.

Trenching operations through concrete pavement shall meet the most current Pierce County Public Works Department requirements or the requirements of the governing jurisdiction involved. Asphalt paving shall be cut ahead of the trenching equipment to prevent excessive "tearing up" of the surface and to eliminate ragged edges.

Asbestos Cement (AC) Pipe

All work where contact with asbestos cement pipe is necessary shall comply with the procedures as required by W.A.C. 296-62 and W.A.C. 296-65. Existing asbestos cement pipe in public right-of-way or public easements may be abandoned in place when at least 3' of non-asbestos material cover is maintained. Mains shall be capped at each end with cement mortar prior to abandonment. Existing water mains (including asbestos cement pipe) to be abandoned in Pierce County right-of-ways will be abandoned per the executed and most current agreement between Spanaway Water and Pierce County Public Works and Utilities Department in place at the time of construction.

Asbestos Cement (AC) Pipe - Removal, Packaging, Transport, and Disposal

When the contract drawings specify or it is otherwise necessary for the contractor to come into contact with or work on asbestos cement pipe, he/she shall comply with the procedures as required by WAC 296-62 and WAC 296-65.

For the most current information on the proper removal, packaging, transport, and disposal of asbestos materials contact the Puget Sound Clean Air Agency (PSCAA) at 1-800-552-3565 or at www.pscleanair.org

Contractor shall complete the PSCAA "Asbestos Waste Material Shipment Record" form and obtain signatures for all parties as indicated on the form:

- Operator
- Transporter(s)
- Waste Disposal Site (WDS) representative

Contractor shall provide fully signed 'Asbestos Waste Material Shipment Record' forms to Spanaway Water Company for all shipments. These signed and certified forms must be provided to SWC prior to final approval and release of contract retainage.

Contractor is responsible for compliance with state/federal/local safety rules and removal, packaging, haul off, and disposal of existing AC pipe including all labor, material, equipment, and tools necessary for (or incidental to) removal and disposal of AC pipe. This shall include: contractor's payment of Waste Disposal Site (WDS) fees, contractor completion of PSCAA's 'Asbestos Waste Material Shipment Record' forms and obtainment of all required signatures on PSCAA forms.

Undermining Of Asbestos Cement Water Main

Spanaway Water Company requires that any existing asbestos cement (A.C.) water main undermined by side sewer installation or other utility installation or construction work must be replaced with ductile iron pipe. See SWC Standard Detail. The pipe connection shall be made with approved compression couplings placed back to solid ground a minimum of two feet past each side of the undermining trench. A SWC inspector shall be on-site when the AC main is exposed and during any and all AC main replacement. When AC main is exposed or replaced, the backfill shall be pea gravel or controlled density fill (CDF).

When boring under an existing (AC) water main the following requirements will apply:

- a) A section of the AC main will be replaced with ductile iron main of the same size if the vertical clearance from the top of the bore hole to the AC pipe is less than four (4) feet.
- b) The length of the replacement pipe shall extend at least two feet past each side of the crossing bore hole.

Bedding

Course sand bedding is required for all service lines, outside of the conduit pipe (see Typical Road Cross Section detail). Bedding for system operating valves, hydrant maintenance valves, air/vacuum relief valves, and blow-off assemblies shall be 5/8 minus gravel, as shown on the appropriate Standard Details. All excavated, exposed, or undermined active AC or PVC water mains shall be bed in pea gravel to the crown of the pipe (minimum) prior to backfilling.

Pipe bedding material, unless otherwise specified and noted on the design drawings, shall be 5/8" minus crushed aggregate, and shall be placed a minimum of 6" above the crown of the pipe. No blocking of any kind shall be used to adjust the pipe to grade. Bell holes shall be dug as required to assure uniform support along the pipe barrel. Where excavation is required below the normal grade line because of poor soil conditions, the base shall also be 5/8" minus crushed.

Backfilling Trenches

Backfilling and surface restoration shall closely follow installation and inspection of the pipe, so that no more than 500 feet of pipe is left exposed. The backfill over the pipe zone material shall be placed and compacted in layers not more than 12-inches thick, except that under roadways, all backfill material shall be placed in layers not more than 6-inches deep and compacted to the density of the existing sub grade. **All backfill and compaction shall be must meet the requirements and approval of the Pierce County Public Works and Utilities Department (or local governing jurisdiction) and their assigned inspectors.** Compaction shall be performed by acceptable methods as required by the agency having jurisdiction. The use of CDF backfill in pertinent situations may be required.

VALVES

The minimum requirements for all gate valves, material and workmanship shall conform to the Standards of AWWA C-500, and will be resilient seat type only.

Buried gate valves shall be epoxy coated iron body, bronze mounted, resilient wedge, and non-rising stem type. Operating stems shall be equipped with standard two- (2) inch operation nut, and O-ring stem seals, suitable for installation with the type and class of pipe being installed. Valves and valve boxes shall be installed in the pipeline at the locations shown on the design drawings or as specified. Upon delivery to the work site, all valves shall be opened to prevent the collection of water in the valve. Valves shall have the interiors cleaned

of all foreign matter and shall be inspected both in open and closed position prior to installation. If any part of the coating is damaged, repairs shall be made by the Contractor at his expense and in a manner satisfactory to the Company

The valves shall be set with stems vertical. The axis of the valve box shall be common with the axis projected off the valve stem. The tops of the adjustable valve boxes shall be set to the existing or established grade, whichever is applicable. Valves and valve boxes shall be set plum, valve boxes shall be placed over the valve or valve operator in such a manner that the valve box does not transmit shock or stress to the valve. Gravel backfill shall be carefully tamped around the valve box to a minimum distance of two feet on all sides or to the undisturbed face of the trench if it is closer.

All valves with operating nuts located more than 42" below finished grade shall be equipped with extension stems to bring the operating nut to within 12" to 24" of the finished grade. At the top of the extension stem, there shall be a two-inch (2") standard operating nut, complete with a centering flange that closely fits the five-inch (5") pipe encasement of the extension stem. The valve box shall be set in a telescoping fashion around the five-inch (5") pipe cut to the correct length to allow future adjustment up or down.

Resilient Seat Gate Valves

Valves shall be resilient seat and approved by the SWC. All gate valves shall conform to ANSI/AWWA C509-87 or C515 Standards for resilient-seated disc gate valves. The valves shall be ductile iron-bodied, iron or ductile iron disk, completely encapsulated with polyurethane rubber. The valve shall be equipped with a bronze, non-rising stem with "O" ring seals. The polyurethane sealing rubber shall be permanently bonded to the disk to meet ASTM tests for rubber to metal bond ASTM D429. All valves shall be rated for 250 psi or higher. The valves shall open counter-clockwise and be furnished with 2-inch square operating nuts except valves in vaults shall be furnished with hand wheels. All surfaces, interior and exterior shall be fusion-bonded epoxy coated in accordance with AWWA C550, acceptable for potable water.

Butterfly Valves

Install 'butterfly' style valves when called out on the applicable design drawing. The valves shall be Henry Pratt Company "*Groundhog*", or SWC approved equal. Butterfly valves shall be of the tight closing rubber seat type with rubber seat either bonded to the body or mechanically retained in the body with no fasteners or retaining hardware in the stream of flow. The valves may have rubber seats mechanically affixed to the valve vane. Where threaded fasteners are used, the fasteners shall be retained with a locking wire or equivalent provision to prevent loosening. Rubber seats attached to the valve vane shall be equipped with stainless steel seat ring integral with the body, and the body internal surfaces shall be epoxy coated in accordance with AWWA C550 to prevent tuberculation buildup which might damage the disc-mounted rubber seat.

No metal-to-metal sealing surfaces shall be permitted. The valves shall be bubble-tight at rated pressures with flow in either direction, and shall be satisfactory for applications involving valve operations after long periods of inactivity. Valve discs shall rotate ninety (90) degrees from the full open position to the tight shut position. Valves shall meet the full requirements of AWWA C504, Class 150B.

Valve Boxes

Each valve shall be provided with an adjustable two-piece cast iron valve box of five inches (5") minimum inside diameter. Valve boxes shall have a top section with an eighteen-inch (18") minimum length. The valve boxes shall be 'heavy duty' with 'dipped' coating manufactured by East Jordan Iron Works (product numbers 00366918, 85556024, and 85556036). All covers shall have the words "Spanaway Water" and the Company logo cast in relief in the top. SWC logo covers have historically been available through 'H. D. Fowler Company', 'Ferguson Water Works', and 'HD Supply - Waterworks'. All covers shall be painted blue. The 'ears' of the valve cover shall be aligned with the direction of the pipe it is controlling. All valves and valve clusters will require concrete collars. In paved areas, valves shall be paved

over then cut out (no square edges), brought up to the new finished grade, concrete collars poured, then asphalted. The concrete collar pad size and location for valves and valve clusters located outside of pavement will be specified on the design drawings and constructed per the Standard Detail.

Tapping Sleeves & Tapping Valves

Tapping valves shall be provided with a standard mechanical joint outlet for use with ductile iron pipe and shall have oversized seat rings to permit entry of the tapping machine cutters. In all other respects, the tapping valves shall conform to the resilient seat gate valves herein specified with regards to operation and materials.

Combination Air Release/Air Vacuum Valves

Two-inch air and vacuum release valves shall be installed at principal high points in the system as directed by SWC. Installation will be located at the high point of the line as shown on the project's Design Drawings. The water line must be constructed so the air release valve may be installed in a convenient predetermined location.

Air and vacuum release valves shall be "APCO" brand standard single body combination air release/vacuum valve, or approved equal. All piping and fittings shall be brass. Air and vacuum release valves will be located within the right-of-way, typically outside of the paved roadway as shown on the Design Drawings. Valve box and covers shall be designed to carry the appropriate traffic loadings. When located within the street section or driving shoulder they shall be designed to carry HS-20 loading. Installation and plumbing guidelines shall be as shown on the Standard Detail.

Sample Stations

Water sampling station stubs shall be installed and located as designated on the approved Design Drawings and shall meet all of the requirements of 'Service Lines' as described in these specifications. Water sampling stations shall be installed by SWC.

Pump and Pressure Reducing Stations

Pipe, fittings and equipment shall be constructed per the requirements shown in the Design Drawings or as specified by the Water Company or Water Company's Engineer. Drain lines from pumps and other equipment shall be piped to an approved below grade drainage system, adhering to the most current Cross-Connection Control requirements.

Valve Marker Post

For each valve outside of asphalt, provide three (3) reference points on the as-built mark-ups with the measurements and directions necessary for future locating in lieu of installing concrete marker posts.

HYDRANTS

Fire Hydrants

All fire hydrants shall be "Mueller Super Centurion 250", "AVK 2780 Nostalgic", or "M & H Style 129 S" (grease lubricant only, not oil). Fire hydrants shall be approved by the National Board of Fire Underwriters and conform to AWWA Specification C502, breakaway type, in which the valve will remain closed if the barrel is broken. The hydrant barrel shall have a diameter of not less than seven inches (7"), and the valve diameter shall be not less than five-and-one-quarter inches (5-1/4"). Each hydrant shall be equipped with two (2) two-and-one-half-inch (2-1/2") hose ports (National Standard Thread). One (1) four-and-one-half-inch (4-1/2") pumper connection (National Standard Thread). A permanent five inch (5") 'Storz' hydrant adapter and 'Storz' blind cap will be installed. Each hydrant shall be equipped with a suitable positive acting drain valve and one-and-one-quarter-inch (1-1/4") pentagonal operating nut (counter-clockwise opening).

Romac brand GripRing™ part #21AMF706GRAPDI pipe restrainer system (MJ gasket, ductile iron

grip ring, special MJ gland, T-bolts) shall be used to restrain the hydrant maintenance gate valve and fire hydrant. The spool (hydrant lead) between the gate valve and fire hydrant shall be six-inch (6") Class 52 ductile iron pipe. Hydrant spools with length in excess of seventeen feet (17'), or more than one stick of pipe, shall be supplied with field lock restraining gaskets or an MJ sleeve and mechanical joint restraint device.

Hydrants shall be installed plumb, set to finished grade, and shall be as shown in the Standard Detail. The pumper port shall face the street. Where the street cannot be clearly defined or recognized, the port shall face the most likely route of approach and location of the fire truck while pumping. This will be determined by the Pierce County Fire Prevention Bureau.

Hydrants shall be painted the standard 'silver' color as required by 'Central Pierce Fire and Rescue'. CPF&R will allow paints that meet the hydrant manufacturer's recommendations. Sherwin Williams brand 'Silver Brite' (B 59 S 11) has been pre-approved. Verify the proposed paint brand and type with SWC prior to any application. Preparation and application methods shall meet the hydrant and paint manufacturer requirements.

Hydrants shall meet all the requirements of the Pierce County Fire Prevention Bureau and shall not be obstructed by any structure or vegetation. The visibility shall not be impaired for a distance of fifty feet in the directions of vehicular approach to the hydrant. Hydrants shall be installed along the main line at the locations shown on the design drawings. A three-foot minimum radius unobstructed working area shall be provided around all hydrants, including future improvements such as trees and plants, fences, rock walls, etc.

Between the time that the fire hydrant is installed and the completed facility is approved and placed into operation, the fire hydrant shall at all times be wrapped in black plastic, or covered in some other suitable manner to clearly indicate that the fire hydrant is not in service.

Blow Off Assembly

Two-inch blow off assemblies shall be installed at the terminus of all dead end water mains and as located on the approved Design Drawings. Blow off assembly installation shall include connection piping, brass ball valve curb stop, valve box, and all accessories. Installation and plumbing shall be as shown on the Standard Detail. Thrust blocking shall not butt against the 2" riser pipe. Block with a slotted length of 6" ductile iron pipe from the end cap to the ecology block.

The blow off assembly will be located as shown on the approved Design Drawings. Valve box and covers shall be designed to carry the appropriate traffic loadings. Blow-off boxes shall conform to that shown in the Standard Detail. When located within the street section or driving shoulder the boxes shall be designed to meet HS-20 loading requirements. Blow offs utilized by the Contractor for flushing the water main shall be sufficient size to obtain 2.5 feet per second velocity in the main.

SERVICE CONNECTIONS

All water service saddles, corporation stops, curb stops and plumbing appurtenances shall be installed within the road right-of-way or utility easement and shall be in conformance with the Standard Details. All brass fittings shall meet the "lead free" standards as defined under Public Law 111-380, the "Reduction of Lead in Drinking Water Act". All water services shall be installed with saddles, regardless of the type of water main material encountered.

Service Lines

Minimum size service lines between the water main and the water meter shall be one (1) inch IPS unless otherwise specified. All service lines shall be the minimum size(s) specified by the County Plumbing Code in accordance with the proposed fixture units or the SWC Standards. All service lines will require individual 4" PVC conduit pipe, except on short side services for R&R projects.

Plastic service pipe (1", 1.5", 2") shall be manufactured from high molecular weight polyethylene (average molecular weight of 1,750,000) defined by ASTM-D2239 as polyethylene Type III (3306) (PE). Pipe shall be made of all virgin material and conform to SC-255-63. The pipe shall be municipal service line size

(1" typical). The pipe shall have a working pressure of 250 psi at 73.4 degrees F for 1,000 hours. The pipe must carry the NFS seal of approval and shall be approved by the Company.

Install 4-inch PVC conduit pipe over the curb stop (5/8" x 3/4" and 1" services). This conduit shall be cut to just below the bottom of the meter box, capped, and left unblocked to allow SWC access to the curb stop.

Sand bedding is required as shown on the Standard Details. **Appropriate sand bedding must be in place and visible after all joint trench and grading work is completed. Water system construction will not pass final inspection if the sand bedding is not present as shown on the water service Standard Details.** All existing service lines cut or damaged during construction shall be replaced in their entirety, from the main line to the service curb stop.

Conduit Pipe

Service line conduit shall be 4-inch schedule 40 PVC. Service lines shall have individual conduits; shared conduit is not acceptable. Conduit pipe shall be white only. Polyethylene pipe may be used under special conditions and retrofit situations when previously approved by SWC. All water service installation shall be in conformance with the Standard Detail.

Setters, Meters and Boxes

The setter, meter, and meter box installation will be made by the Contractor for all new plat and commercial development work. Approximately six feet of one-inch polyethylene pipe shall be stubbed out of the customer side of the setter and extend a minimum of 36" above the ground. This stub shall initially be taped to prevent material from entering the customer side service line. Following completion and successful testing of the water system, this tape shall be replaced with a cap. A 'jumper' shall be installed for flushing purposes. The pressure test will be conducted against the setter's angle stop. The angle stop shall remain closed and locked for the duration of the project except during flushing. Meters will be supplied by SWC per the project's 'Water Service Agreement'. Water service will not be granted on systems until they are fully completed and approved by SWC. At the end of the project the Contractor will correct any meter boxes and setters that are not at the proper grade. Connection must be made to the stub; direct connection to the setter is not permitted.

The setter and meter box installation will be made by the Developer for all main replacement and restoration work within the existing system. The Developer shall provide the water service fittings and appurtenances as shown on the Standard Detail drawing. Meters will be installed by SWC staff unless otherwise directed within the project's construction specifications.

Abandoned Services

Abandoned service lines shall have the pipe saddle and all hardware removed. **A stainless steel, full circle repair band, "Ford Style FS1", or approved equal, shall be installed on the main per manufacturer specifications.**

INSPECTION, DISINFECTION, AND TESTING

Only SWC personnel will be allowed to operate existing and new control valves. The Contractor's personnel are expressly forbidden to operate any valve on any section of line that is part of or connected to the existing water system or new construction that has been accepted by the Company.

All pipelines shall be disinfected, pressure tested, and tested for water quality prior to acceptance of work. The continuity of the installed locate wire (mains and services) will also be tested as part of the final system acceptance.

Construction Staking

All surveying and construction staking will be the responsibility of the developer/owner (unless otherwise stated within the project specifications prepared by SWC) and be performed by an engineering or surveying firm capable of performing such work. The engineer or surveyor directing such work will be

licensed by the State of Washington. Staking will be maintained throughout construction. The preconstruction meeting will be held with SWC prior to commencing staking. All construction staking will be inspected by SWC prior to construction. The minimum staking of waterlines will be as follows;

- Stake centerline alignment every 50 feet with cuts and/or fills to bottom of trench maintaining 36 inches to 42 inches of cover over pipe (36 inch minimum). Centerline cuts are not required when road grade is to finished subgrade elevation.
- Stake location of all fire hydrants, hydrant flange elevations, tees, valves, fittings, water meters, setters, and other fixtures with cut or fill to finished grade. Label stakes with offset distance and elevation reference to proposed finished grade adjacent to the hydrant, valve, bend, tee, or other appurtenance.
- Place stakes at all crossings of storm sewers and sanitary sewers. Label stakes with top of pipe elevations at the crossing for water mains and sewer mains to ensure proper depth and vertical separation.

A cut sheet shall be provided showing cuts to flow-line grade, finished grade and all other applicable information. Each installed pipe shall be checked for line and grade before proceeding with the next pipe. Line and grade may be taken from curb or pavement when such structures parallel the work and shall conform to elevations and distances shown on the Drawings. Revision of pipe alignment and/or grade may be required by the Inspector in the field should obstructions or unsuitable conditions be encountered, or an obviously more suitable location is evident.

Construction Inspection

The developer's contractor shall schedule a pre-construction meeting with a SWC inspector and the Water Company's designated engineer two weeks prior to the commencement of any water installation work. The contractor shall make all water system materials available for inspection by SWC prior to any installation. All water main and facilities installation shall be inspected by a SWC representative and/or the Water Company's designated engineer during construction. The following items shall **NOT** be backfilled until visual inspection and explicit authorization to backfill by a Spanaway Water Company inspector;

Fittings (tees, crosses, reducers, bends, etc.)

Thrust blocks

Valves and valve clusters (crushed rock bedding, boxes and lids, locate wire etc.)

Fire hydrants (drain rock, concrete bearing block, thrust block, restraints, filter fabric, etc.)

Blow-off assemblies (all pipe and fittings, gravel backfill, thrust block w/slotted pipe, etc.)

Service taps and stubs (saddles, stops, fittings, conduit, locate wire, markers, sand bedding, etc.)

Storm crossings with 1' or less vertical separation

Storm crossings with 3' or less horizontal separation

Sanitary sewer crossings with less than 1.5' vertical separation

Any and all constructed or installed facilities that have been backfilled prior to specific inspection will be exposed by the contractor at his expense at the request of the inspector. All materials found during the progress of work to have cracks, flaws, or other defects shall be rejected by the inspector and/or the engineer. All defective materials furnished by the contractor shall be promptly removed by him from the site.

The contractor must leave the main exposed every 50 LF or less until SWC personnel capture its location with GPS equipment. All fittings, excluding service saddles, must also be left exposed until surveyed.

All service stub sand bedding will be re-inspected during and after the dry utilities joint trench is backfilled and graded to ensure adequate sand bedding around the water service stubs. **It is the responsibility of the contractor to ensure that all service stubs have adequate sand bedding after all joint trench work has been completed. Water system construction will not pass final inspection if the sand bedding is not present as shown on the Standard Detail.**

Final inspection for water system facilities will only be provided after all paving, sidewalk installation, and joint trench work has been completed.

The developer's contractor shall work to avoid utility conflicts. When conflict with joint trench utilities is unavoidable, water service lines, curb stops, and stubs shall be raised and placed above other utility conduits and lines. All inspection services will be billed to the owner/developer at the current hourly rate. Inspection services required outside of the SWC normal work day will be considered overtime additional and billed to the owner/developer at the current overtime hourly rate.

Non-Water Construction and Inspection

Contractors installing non-water facilities located near or impacting existing water facilities (e.g. side sewers crossing under AC water main) shall notify SWC prior to any construction work. The contractor will follow all SWC procedures, practices, and 'Standard Construction Specifications' regarding the cutting, removal, and/or relocation of any part of the water distribution system. SWC's inspector shall be present any time water facilities are exposed and shall direct the coordination of all water facility or water related work being performed by the contractor. This shall include, but will not be limited to, new main construction, main and service line replacement and/or the temporary disconnection of service to SWC customers. Inspection services related to non-water utility construction, services related to the physical relocation or repair of water facilities or the protection of facilities will be considered additional and billed to the contractor/developer at the current hourly rate. Inspection services performed outside of the SWC normal work day will be considered overtime additional and billed to the owner/developer at the current overtime hourly rate.

Any and all service lines cut or damaged during construction shall be replaced in their entirety, from the main line to the service setter.

For requirements regarding work with and around Asbestos Cement (AC) water mains see 'Asbestos Cement (AC) Pipe' and 'Undermining of Asbestos Cement Water Main'.

Disinfection of Water Mains

All new water mains and repaired portions of existing mains shall be disinfected and a satisfactory bacteriological report obtained before being placed in service. As sections of pipe are constructed and before pipelines are placed in service, they shall be disinfected as required by the Washington State Department of Health. Disinfection shall be performed in accordance with the requirements of AWWA C-601 except as modified herein.

Dry calcium hypochlorite in granular form shall be placed within the pipeline and appurtenances as construction progresses. Calcium hypochlorite shall be placed in sufficient quantities and at such location to obtain a solution of not less than 50-mg/L available chlorine throughout the entire project. Filling of pipeline using this method should be at a very slow, controlled rate. Pipeline should be filled within two (2) days of placing sterilizing agent. In the process of disinfecting newly laid pipe, all valves, hydrants, and/or other appurtenances shall be operated while the pipeline is filled with the chlorinating agent and under normal operating pressure. Chlorinated water must remain in the pipeline for a minimum of 24 hours.

The project inspector (or as called out within the design drawings) may require the Contractor to swab the inside of a designated pipe length or fitting with a chlorine solution prior to installation. All swabbing shall be performed with a chlorine solution of at least 200 ppm using approved equipment (appropriately sized 'pig'), materials and chemicals. Inspector shall witness the swabbing procedure and document results.

The Contractor shall provide all necessary appurtenances, materials and equipment for disinfection of the mains. All tapping of the pipe for the convenience of the Contractor's operations shall be made with service saddles fitted with corporation stops. Abandoned service lines shall have the pipe saddle and all hardware removed. A stainless steel, full circle repair clamp, "Ford Style FS1", or approved equal, shall be installed per manufacturer specifications. The Contractor shall record and reference the location of each tap so it can be accurately shown on the "As-Built" drawing.

Following disinfection, all chlorinated water shall be flushed from the disinfected system until the replacement water throughout its length shows a residual that is not in excess of that normally carried in that

portion of the system.

In all disinfection processes, the Contractor shall take particular care to ensure that chlorinated water does no physical or environmental damage to property, streams, storm sewers or any waterways. The Contractor shall chemically or otherwise treat the chlorinated water to prevent damage to the environment particularly that of receiving streams, ponds, or wetland areas. Disposal of chlorinated or de-chlorinated water shall be the Contractor's responsibility. Methods and materials shall conform to any special requirements and permits mandated by Pierce County Public Works and/or the State of Washington Department of Ecology.

If after filling the main, the solution strength in any location is less than 50 mg/L available chlorine, then the pipe shall be re-chlorinated using liquid chlorine injection. Chlorine shall be re-introduced into the system utilizing a standard pressure pump until solution strength of 50 mg/L available chlorine is detected in all locations of the newly constructed distribution system.

Flushing of Water Mains

Spanaway Water Company will be responsible for flushing newly constructed water mains. The Contractor shall be responsible to bleed air from service lines via the setter. All air shall be expelled. The Contractor will provide SWC an appropriate location to flush the new main. The flushing location provided must be able to adequately accept the total volume of flushed water. Contractor shall coordinate with the Water Company (48 hour notice) to schedule flushing after completion of a successful pressure test of the main which has been witnessed and accepted by SWC and their engineer.

Water Quality Tests

The Water Company or their representative will take coliform bacteria tests. Satisfactory results must be received prior to facilities being placed in service. Drinking water must not be furnished to the consumer until satisfactory bacteriological sample results have been obtained. The estimated cost for bacteriological sampling is included within the projects development fees. Additional sampling, for any reason, will be charged additionally to the project

Should the bacteriological test prove the water is unsatisfactory for drinking water; the Contractor may proceed directly with repeating the disinfection procedure. Sampling and disinfection shall be repeated at the Contractors expense until bacteriological test results prove the water is satisfactory for drinking water. There shall be no additional costs to the Company for repeating disinfection or for additional sampling. Failure to obtain satisfactory test results shall be considered as failure of the Contractor to keep the pipe clean during construction, or to properly disinfect the main. Costs for any additional testing due to initial failed test results will be charged to the project.

Hydrostatic Pressure Test

Two pressure tests are required. Water main appurtenances and service connections shall be tested in sections of convenient length, first under a minimum hydrostatic pressure of 225 psi with curb stops closed, then to a pressure of 140 PSI with the curb stops open and the angle stops closed. PSI shall be measured at the highest point of the section of line being tested. Sections to be tested shall normally be limited to 1,500-feet. Longer lengths must be approved by the SWC or the Engineer, to be based on valve spacing. The Engineer and/or SWC may require that the first section of pipe, not less than 1,000-feet in length, installed by each of the Contractor's crews, be tested in order to qualify the crew and the materials. Pipe laying shall not be continued more than an additional 1,000-feet until the first section has been tested successfully. The Contractor shall determine the lengths and spacing of the various sections of pipe to be tested to meet these pressure test requirements. Temporary caps and blocking shall be used if the test cannot be made against closed valves. All PVC pipe shall be tested at the pressure class of the pipe.

Pumps, gauges, plugs, saddles, corporation stops, miscellaneous hose and piping, and measuring equipment necessary for performing the test shall be furnished and operated by the Contractor. The pressure gauge used for the test shall not exceed 400 psi. The Company's Engineer or their representative will verify conformance to prescribed specifications and procedures.

All service lines shall be charged through the individual service connection curb stops for the 225 PSI pressure test, then to the setter's angle stop for the 140 PSI pressure test. (Setter components are rated for a maximum PSI of 140 and shall thereby be excluded from the 225 PSI pressure test.) Hydrostatic tests shall be performed on every complete section of water main between two valves, and each valve shall withstand the same test pressure as the pipe with no pressure active in the section of pipe beyond the closed valve.

The pipeline shall be backfilled sufficiently to prevent movement of the pipe under pressure. All thrust blocks shall be in place and inspected before testing. Where permanent blocking is not required, the Contractor shall furnish and install temporary blocking and remove it after testing.

The mains shall be filled at a slow, controlled rate with water provided only by SWC. **The use of water trucks for pressure testing, or for any other purpose in or around the water system is not allowed.** Water will stand under pressure a minimum of 24 hours to allow the escape of air and allow the lining of the pipe to absorb water. Contractor shall expel all air from service lines; SWC will expel air through hydrants and blow off valves. The Company will furnish the water necessary to fill the pipelines for testing purposes at a time of day when sufficient quantities of water are available for normal system operation.

A sterilized container (such as a new 55 gallon garbage can with a clean liner) shall be used for holding water for pumping up pressure on the main being tested. This makeup water shall be sterilized by the addition of chlorine to a concentration of 50-mg/l. The Contractor shall coordinate and approve the source of the pump up and makeup water with SWC prior to testing. Pressure gauges used in the test shall be accompanied with certifications of accuracy from a testing Laboratory approved by the Engineer.

The test shall be accomplished by pumping the main up to the required pressure, stopping the pump for 15-minutes, and then pumping the main up to the test pressure again. Tests shall be made with the hydrant auxiliary gate valves open and pressure against the hydrant valve. Each valve shall be tested by closing each in turn and relieving the pressure beyond. Only SWC is permitted to operate hydrants, main line valves, and blowoffs; The Contractor may operate service line corporation stops and curb stops. This test of the valve will be acceptable if there is no immediate loss of pressure on the gauge when the pressure comes against the valve being checked. The Contractor shall verify that the pressure differential across the valve does not exceed the rated working pressure of the valve.

Once the Contractor has independently verified that the pipe is in satisfactory condition and no loss of pressure exists, the Contractor shall contact SWC to witness two 30-minute pressure tests. The first 30-minute test at 225 PSI will seat the joints and fittings. Following a second, successful 30-minute pre-test at 225 PSI the Company's Engineer will be called to witness two final pressure tests, first at 225 PSI and then at 140 PSI, lasting a period of not less than 15-minutes. During the tests, the section being tested shall be observed to detect any visible leakage. **There is zero allowable loss of pressure during the test period.** Any visible leakage detected shall be corrected by the Contractor.

Should the tested section fail to meet the pressure test successfully as specified or determined by SWC's Engineer, the Contractor shall, at no additional expense to the Company, locate and repair the defects and then retest the pipeline. The Contractor shall be responsible for any failure and shall repair all damage at his own expense. Whenever it is necessary to replace defective material or correct the workmanship, the hydrostatic test shall be re-run at the Contractor's expense until a satisfactory test is obtained.

Testing Extensions from Existing Mains

When an existing water main is extended with new pipe to a new valve and the distance from the existing pipe to the new valve is 18-feet or less, the section of new pipe installed between the new valve and the end of the existing main shall be made with pretested, pre-chlorinated pipe, and no hydrostatic test will be required. When the required hydrostatic tests are conducted in the new main section beyond the installed new valve in the closed position, the normal pressure of the existing main may be present against the other side of the new valve.

Where the distance between the end of an existing water main pipe extension to the new valve is more than 18-feet, the connection of the new pipe to existing pipe shall not be made until after hydrostatic tests have been made to the required pressure in both directions against the new valve. This shall be accomplished by a temporary cap or plug installed on the end of the new pipe, beyond the new valve, as close as possible to the existing pipe for testing purposes.

The short length of pipe between the temporary cap or plug end with the new valve in the closed position, with no hydrostatic pressure active on the opposite side of the valve, shall be subjected to the required test pressure. The same test shall be made against the other side of the new valve when that section of pipe is tested with no hydrostatic pressure active in the short section of pipe toward the existing main. The final connection to the existing main shall be made with pretested pre-chlorinated pipe.

Fire Flow Test

Fire flow test results are required by Pierce County Fire Prevention Bureau prior to final water distribution system approval. These results verify that minimum fire flow requirements are being met at all hydrant location within the new distribution system. SWC will only accept fire flow test results from qualified professional testers (professional engineer or fire sprinkler company). Tests shall be conducted in accordance with AWWA Standard practices. It is recommended that the procedures outlined in AWWA Manual M17, 'Installation, Field Testing, and Maintenance of Fire Hydrants' be used for conducting flow tests. Prior authorization from SWC's engineer is required to verify which hydrants will be used to measure flow and which will be used to measure static and residual pressures. Select a day for testing when system consumption will be normal (per SWC) and weather predictions indicate that conditions will be reasonable. SWC should be notified, prior approval is required, as to the proposed time and location of the tests.

Hydrants will be opened slowly by SWC until fully opened. Hydrants shall be closed very slowly to avoid water hammer. Hydrants will be opened and closed one at a time to minimize the effect on the distribution system. The developer is responsible for the proper disposal of all water used during the flow test, erosion prevention and site cleanup.

Typical Testing Sequence

The typical sequence for construction testing is as follows;

- Contractor notifies SWC to fill constructed mains with water. All curb stops must be closed.
- SWC personnel will operate all valving required to fill new main lines, working with the contractor to allow air to escape while filling
- Water distribution system will 'cook' for 24 hours (min)
- SWC will flush system
- Contractor shall be responsible to bleed air from service lines
- Contractor will coordinate pressure tests (after pre-test) with SWC and Company's engineer. Curb stops shall be opened and angle stops closed in between the 225 PSI and 140 PSI tests.
- After passing the pressure tests SWC will flush system again
- After 24 hours SWC will pull the first bacteriological sample
- After 24 hours SWC will pull the second bacteriological sample
- After passing the bacteriological tests the contractor may continue with project work, final water inspection will be performed after all joint trench, paving, and sidewalk work has been completed
- Contractor/Developer shall schedule and coordinate fire flow test
- As-built information (signed by the Contractor) will be provided to the Company.

EROSION CONTROL

The detrimental effects of erosion and sedimentation shall be minimized by conforming to the most current Pierce County requirements. Outside of public right-of-way a field investigation of surrounding areas to determine possible erosion control concerns shall be performed by the Developer and/or Contractor

prior to any construction activity. It shall be the responsibility of the Developer and the Contractor to ensure that erosion control measures are in place or adequately available to provide prevention, interception and treatment of all potential silt laden run-off created by construction.

All erosion and sedimentation control shall be per the most current Pierce County design and construction standards. Developer and Contractor shall become familiar with all State and County conditions of required permits, and shall adhere to all conditions and requirements

RESTORATION AND CLEANUP

All restoration must meet the requirements and approval of the Pierce County Public Works and Utilities Department (or local governing jurisdiction) and their assigned inspectors. Where all or portions of the construction is in undeveloped areas, the entire area which has been disturbed by the construction shall be shaped so that upon completion the area will present a uniform appearance, blending into the contour of the adjacent properties.

Slopes, sidewalk areas, planting areas and roadway shall be smoothed and finished to the required cross section and grade. Machine dressing shall be supplemented by hand work to meet requirements outlined herein, to the satisfaction of the Pierce County Inspector, SWC and/or the Engineer. Upon completion of the cleaning and dressing, the project shall appear uniform in all respects. All graded areas shall be true to line and grade.

All excavated material at the outer lateral limits of the project shall be removed entirely. Material resulting from clearing and grubbing or grading operations shall be removed and disposed of appropriately.

Pavement patch shall meet the most current Pierce County Public Works and Utilities Department or local jurisdiction requirements. All pavements and oil mat surfaces, concrete curbs, curb and gutters, walls, and sidewalks whether new or old shall be thoroughly cleaned per the requirements of the Pierce County Public Works and Utilities Department. Castings for water valves, blow off boxes, vaults and other similar installations which have been covered with the asphalt material shall be cleaned to the satisfaction of the Company and/or the Engineer.

Restore to original grades and ensure proper drainage. Place two-inch compacted layer of crushed rock where indicated.

Drainage facilities such as inlets, catch basins, culverts, and open ditches shall be cleaned of all debris that is the result of the Developer and/or Contractor's operations. Clean ditches of all foregoing materials caused by construction. Keep culvert ends free of debris at all times. Rake and smooth back slope disturbed by construction.

When possible all landscape improvements within the construction area in public right-of-way and private property shall be protected and left in place. Where it is necessary to remove existing landscaping improvements, the improvements shall be restored to their original condition or better, to the satisfaction of the Company and property owner. Landscaping improvements damaged by the Contractor's operations shall be replaced at no cost to the Company or property owner.

AS-BUILT INFORMATION

The Contractor shall keep accurate drawing records of all construction to include; pipe length installed; the location of all taps made for services, temporary blow offs and line charging; and all appurtenances installed which may or may not be exposed upon completion (reducers, bends, tees, etc.) for "As-Built" drawing preparation. The following detailed attribute information will be required;

<u>Component</u>	<u>Attributes</u>
Hydrant	manufacturer, model, year, depth of bury
Valve	size, manufacturer, model, year, depth of bury
Blow-off assembly	size, depth of bury
PRV	size, manufacturer, model, year, depth of bury

Air/Vac assembly

size, manufacturer, model, year, depth of bury

No ‘Record drawing’ submittals or construction certification will be made prior to receipt of Contractor’s “As-Built” map records. Projects built “per plan” will require the Contractor’s signed “As-Built” records stating such as well as all ‘component’ information. A copy of these records (signed by the Contractor) will be provided to the Company by the Contractor upon completion of a passing pressure test. Neither Developer nor Developer's Engineer shall have any rights of ownership, copyright, trademark or patent in the Plans.

A copy of any and all billings by the developer’s contractor for the installation of the water system shall be submitted to the Company as part of the Company’s accounting requirements. The information for the specific project will remain confidential.

Easement documents, if applicable, shall be filed and recorded with the Pierce County Auditor's office and the documents reviewed by the Company prior to project acceptance.

GUARANTEE AND WARRANTY

The Developer shall, upon completion of the work and prior to acceptance by the Company, furnish the Company a written guarantee covering all material and workmanship for a period of two years after the date of final acceptance. The ‘Water System Bill of Sale’ for the project provides this guarantee. The Developer shall make all necessary repairs during that period at his own expense, if such repairs are necessitated as the result of furnishing poor materials and/or workmanship, or if installed features do not meet SWC standard specifications as outlined herein. The Developer shall obtain warranties from the contractors, subcontractors and suppliers of material or equipment where such warranties are required, and shall deliver copies to the Company upon completion of the work



SPANAWAY WATER COMPANY, Inc.
POST OFFICE BOX 1000
SPANAWAY, WASHINGTON 98387-1000

18413 ‘B’ STREET EAST
(253) 531-9024

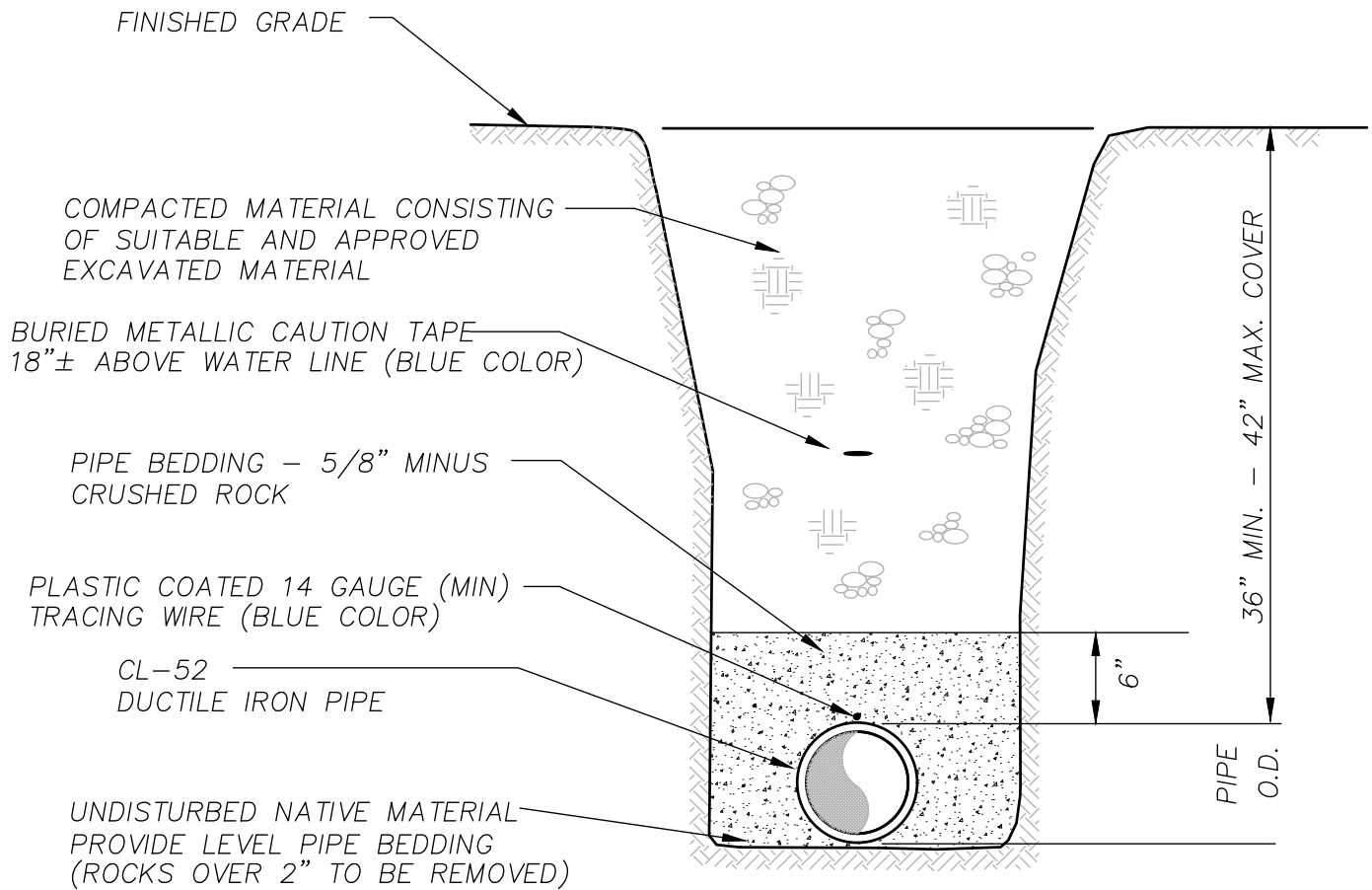

NOTE: BACKFILL FOR ALL ROAD AND DRIVEWAY CROSSINGS MUST MEET THE MOST CURRENT PIERCE COUNTY PUBLIC WORKS DEPARTMENT REGULATIONS AS REQUIRED BY THE RIGHT-OF-WAY INSPECTOR

WATER MAIN TRENCH SECTION

Spanaway Water Company
 STANDARD DETAIL 1



SWC VALVE COVER

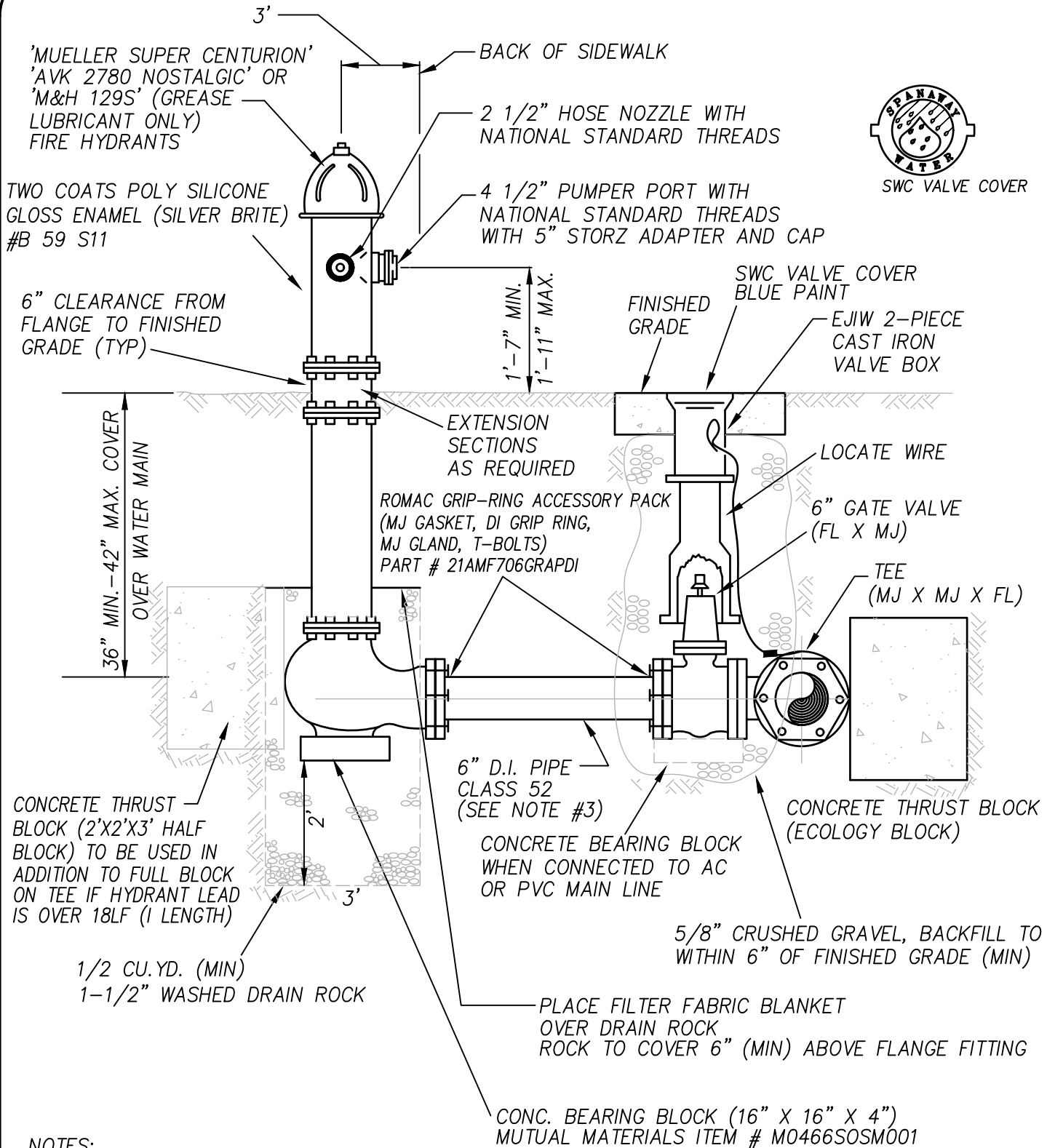

NOTES:

1. 3' MINIMUM FROM BACK OF CURB OR WALK
2. PROVIDE MIN. 3'-0" MINIMUM CLEARANCE AND LEVEL AREA AROUND HYDRANT
3. PROVIDE 1/2 BLOCK BEHIND HYDRANT AND LOCKING FIELD GASKETS FOR ALL HYDRANT LEADS LONGER THAN 18 LF (1 STICK OF PIPE)

FIRE HYDRANT ASSEMBLY

Spanaway Water Company
STANDARD DETAIL 2

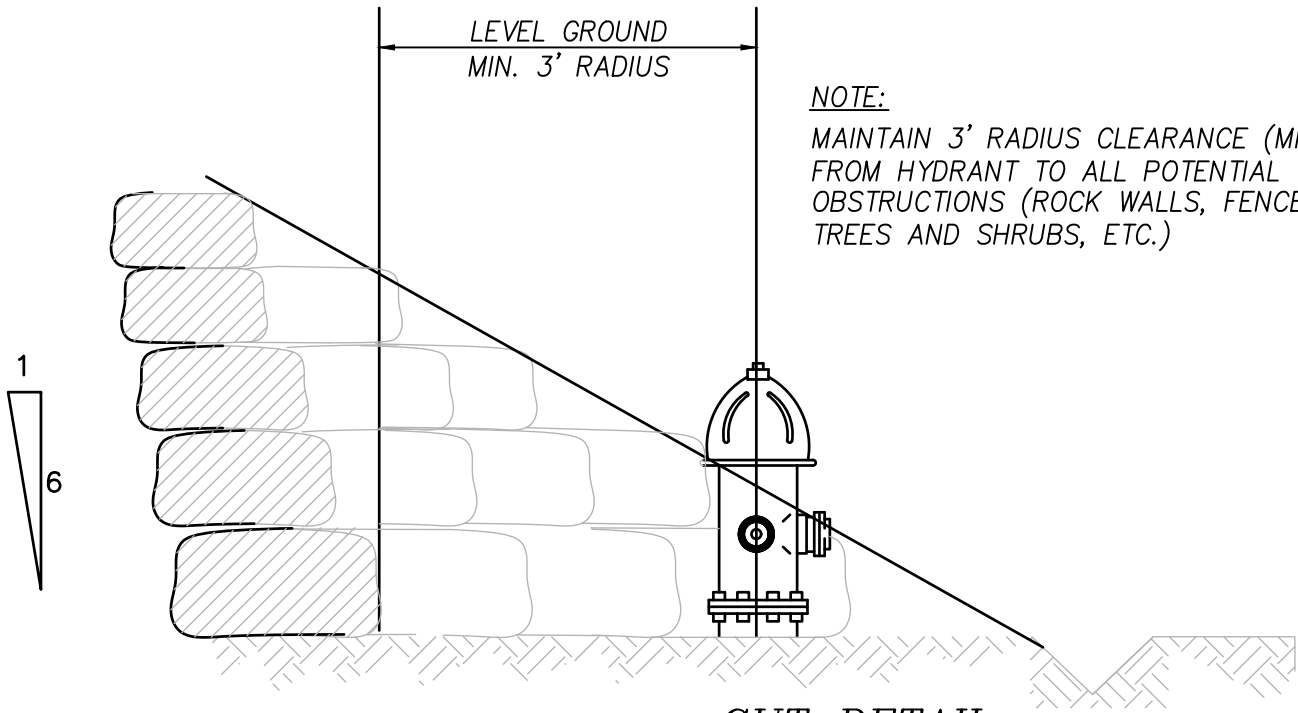

CUT DETAIL

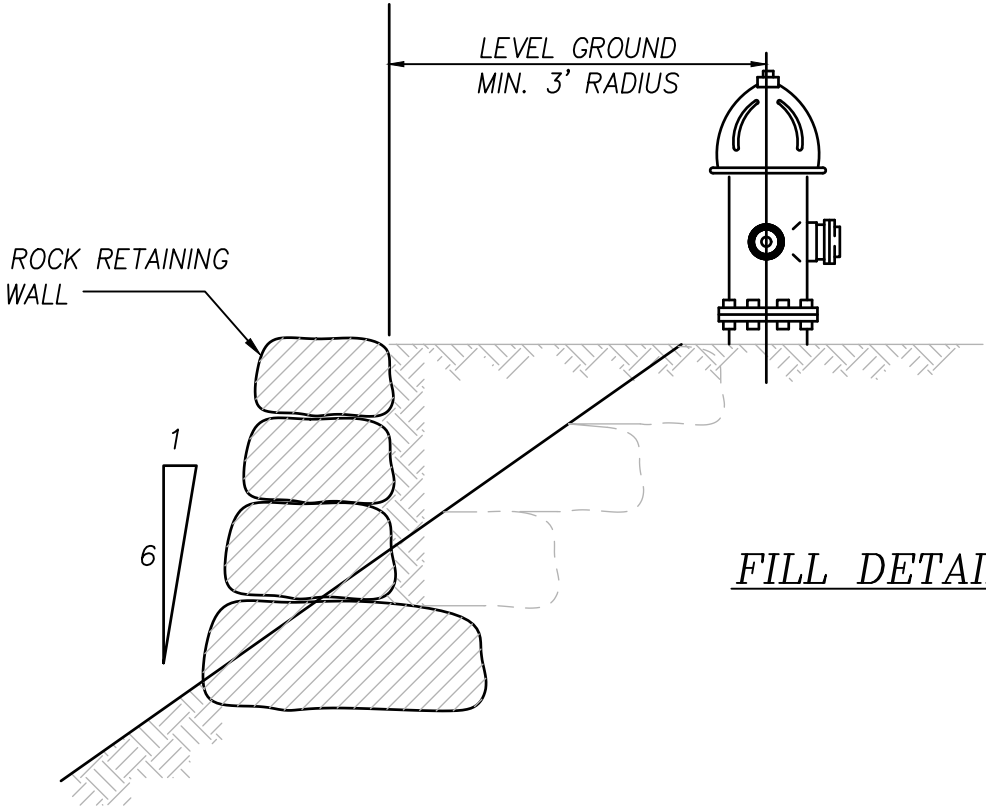

FILL DETAIL

NOTE:
 MAINTAIN 3' RADIUS CLEARANCE (MIN)
 FROM HYDRANT TO ALL POTENTIAL
 OBSTRUCTIONS (ROCK WALLS, FENCES,
 TREES AND SHRUBS, ETC.)

**FIRE HYDRANT
 LOCATED IN CUT OR FILL**

**Spanaway Water Company
 STANDARD DETAIL 3**

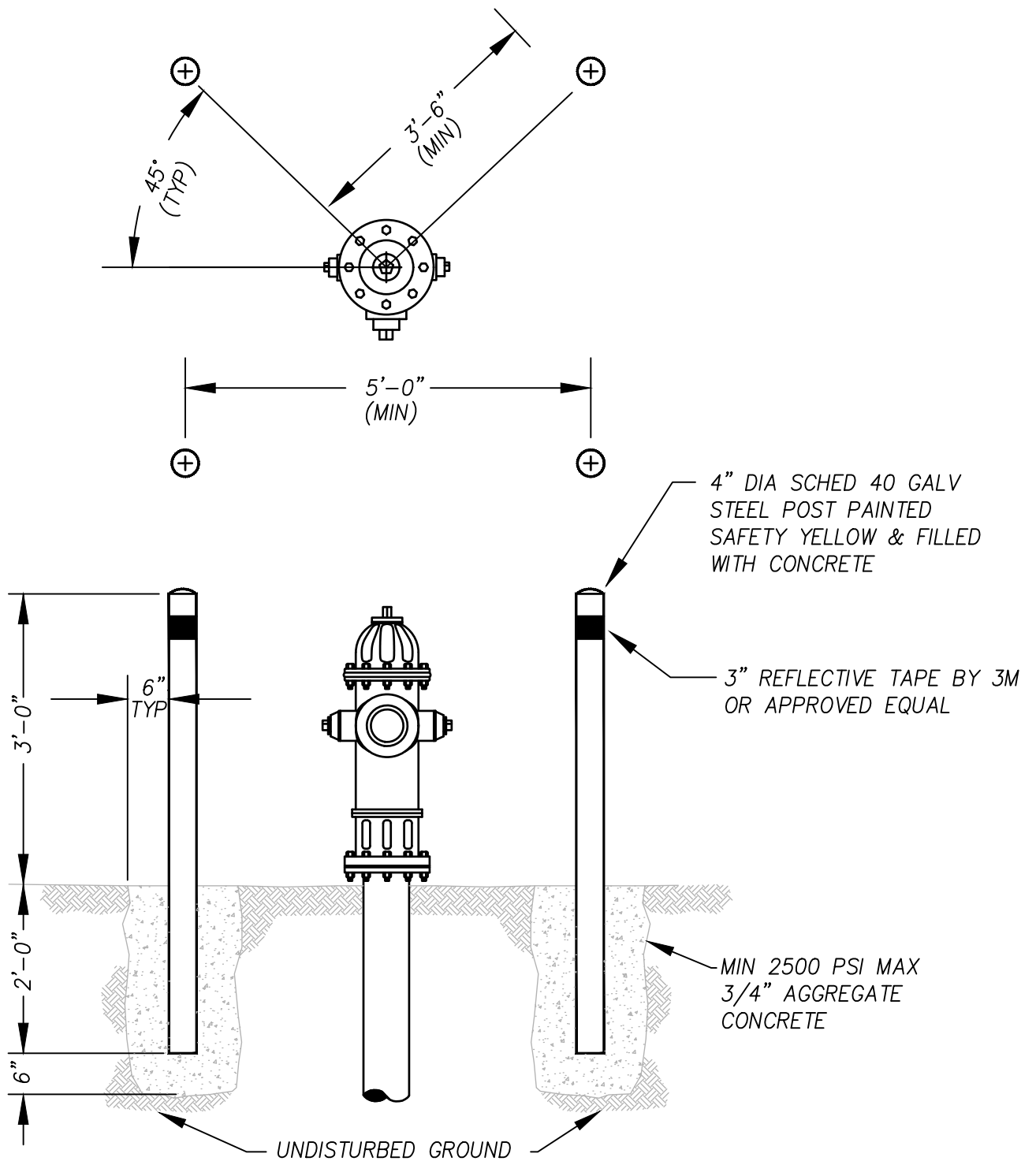

NOTES:

1. TO BE USED IN AREAS WHERE HYDRANTS ARE EXPOSED TO VEHICULAR TRAFFIC AS SHOWN ON THE DESIGN DRAWINGS.
2. POSTS SHALL NOT BE IN DIRECT LINE WITH ANY DISCHARGE PORTS.
2. POSTS SHALL BE 5- FEET IN LENGTH WITH 2- FEET OF BURY.

FIRE HYDRANT BOLLARDS

Spanaway Water Company
STANDARD DETAIL 4

1/2 ECOLOGY BLOCKS (2' X 2' X 3') SHALL BE USED FOR MAINS 12" DIA AND SMALLER
 UNLESS OTHERWISE SPECIFIED BY THE ENGINEER
 FULL ECOLOGY BLOCKS (2' X 2' X 6') WILL BE USED FOR 16" DIA MAINS
 MAINS GREATER THAN 16" SHALL BE PROJECT SPECIFIC - PER THE ENGINEER
 (SEE THRUST BLOCK DETAIL 17)

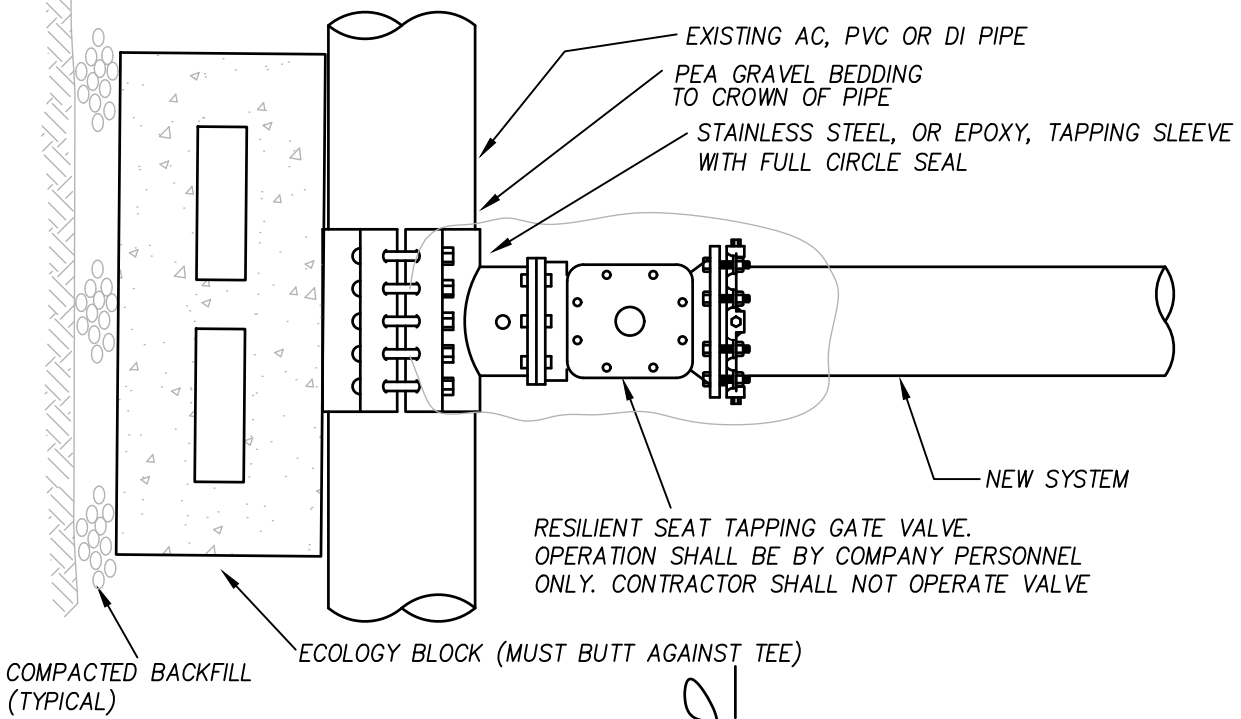

NOTE:

ALL MECHANICAL JOINTS TO USE MEGA-LUG CONSTRUCTION

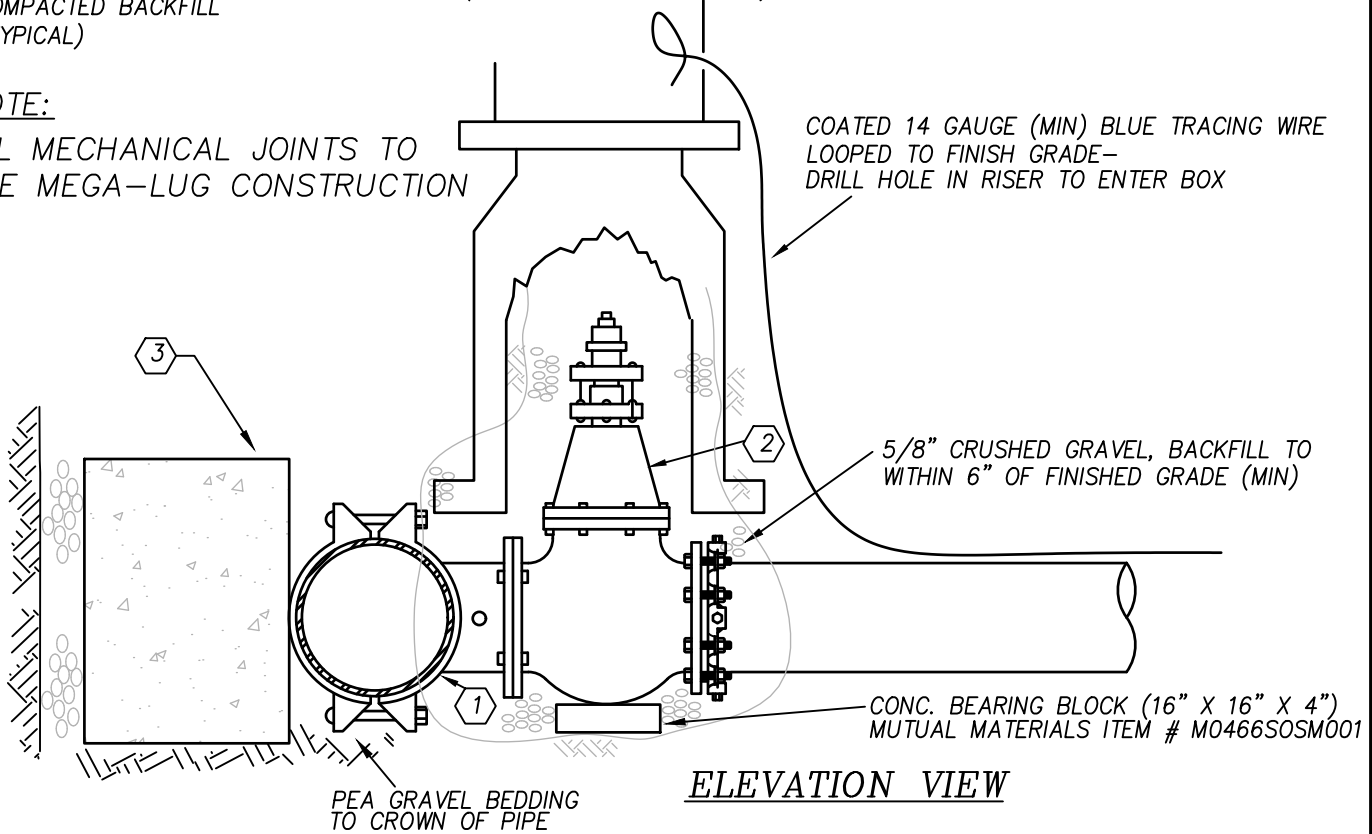

- ① STAINLESS STEEL, OR EPOXY, TAPPING TEE WITH FULL CIRCLE SEAL
- ② RESILIENT SEAT TAPPING VALVE
- ③ ECOLOGY BLOCK (SEE NOTE ABOVE)

ALL EXCAVATED, EXPOSED, OR UNDERMINED AC OR PVC MAINS SHALL BE BED IN PEA GRAVEL TO THE CROWN OF THE PIPE (MINIMUM)

HOT TAP CONNECTION

Spanaway Water Company
 STANDARD DETAIL 5

ALT 1:
 (STERILIZED) ROMAC MACRO (12" MIN LENGTH) OR APPROVED EQUAL FLEXIBLE COUPLING (FOR USE ON AC OR PVC TO DI CONNECTIONS)

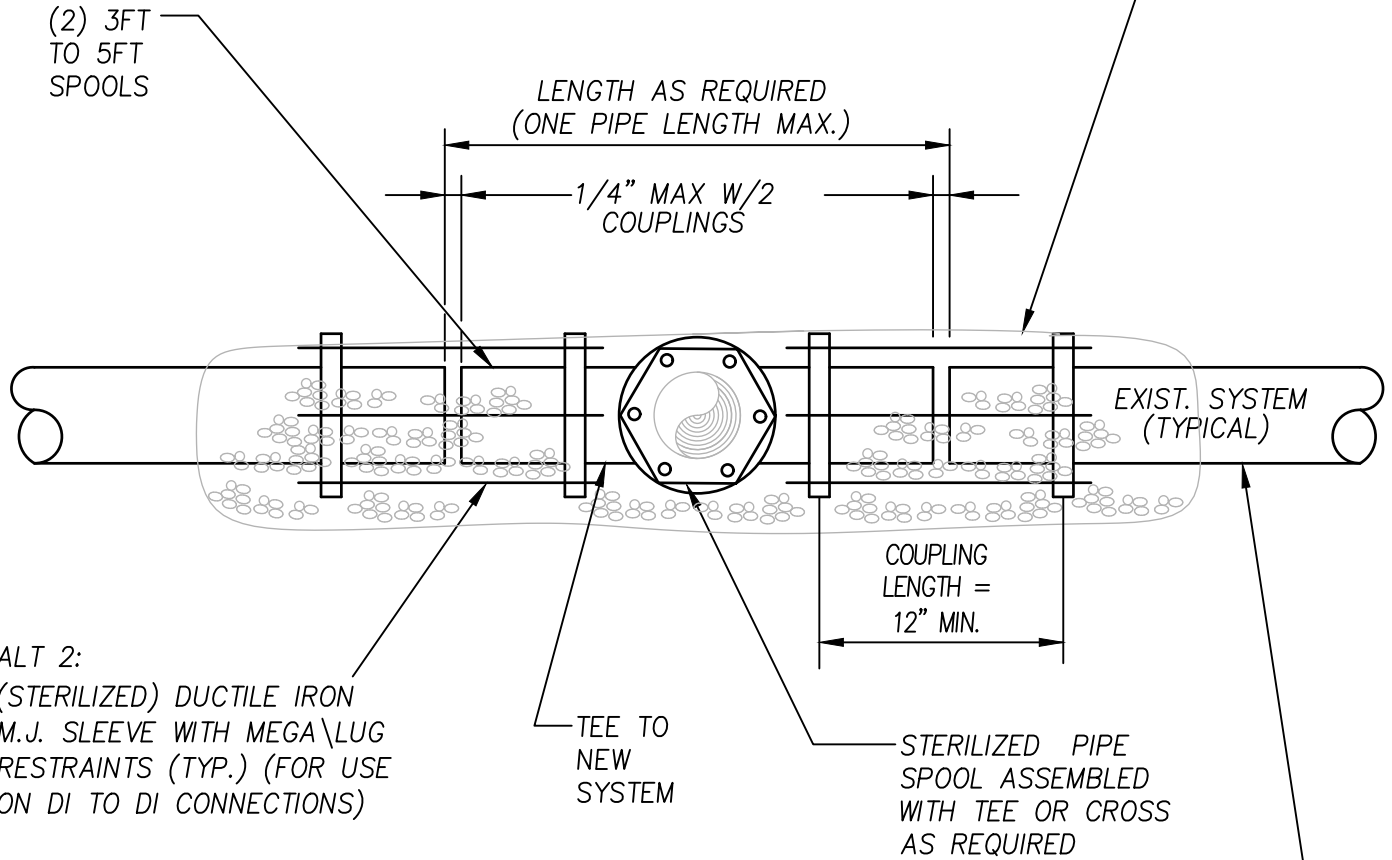

ALT 2:
 (STERILIZED) DUCTILE IRON M.J. SLEEVE WITH MEGA LUG RESTRAINTS (TYP.) (FOR USE ON DI TO DI CONNECTIONS)

ALL EXCAVATED, EXPOSED, OR UNDERMINED AC OR PVC MAINS SHALL BE BED IN PEA GRAVEL TO THE CROWN OF THE PIPE (MINIMUM)

DISCHARGE PRESSURE PRIOR TO REMOVAL OF THRUST BLOCK AND CONNECTION TO EXIST. SYSTEM.

NOTE:
 NO DEFLECTION SHALL BE ALLOWED WITH EITHER COUPLING AT ANY POINT IN THE CONNECTIONS

CUT IN CONNECTION

Spanaway Water Company
 DETAIL 6

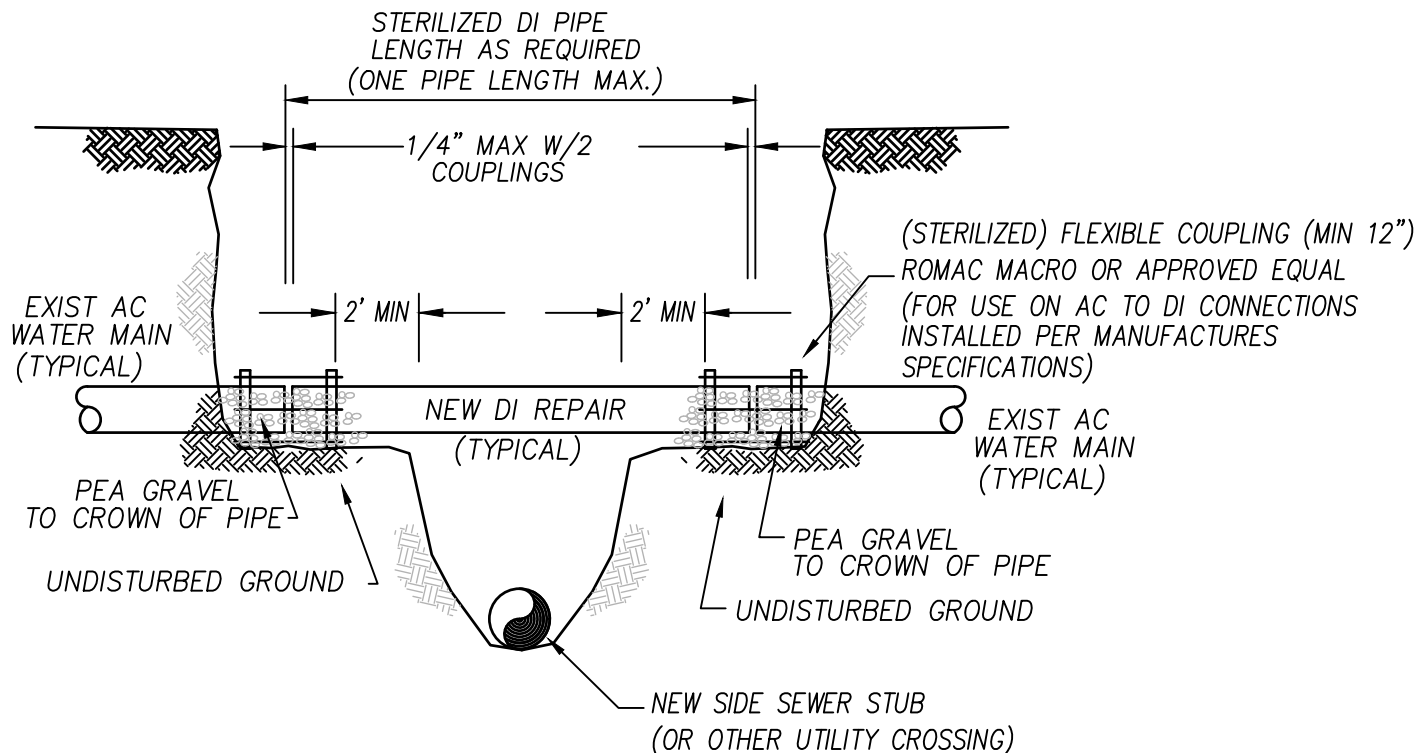

NOTES:

1. ALL EXCAVATED, EXPOSED, OR UNDERMINED AC OR PVC MAINS SHALL BE BED IN PEA GRAVEL OR CDF TO THE CROWN OF THE PIPE (MINIMUM)
2. (STERILIZED) FLEXIBLE COUPLING MIN 12" LENGTH (ROMAC MACRO) (OR APPROVED EQUAL FOR AC TO DI CONNECTIONS)
3. COUPLINGS SHALL BE LOCATED ON UNDISTURBED GROUND A MINIMUM OF 2- FEET PAST THE LIMITS OF THE UNDERMINING UTILITY TRENCH
4. STERILIZED DI PIPE – LENGTH AS NEEDED (ONE PIPE LENGTH MAX.) ALL D.I. PIPE SHALL REST ON FIRM BEARING EARTH
5. CONTRACTOR IS REQUIRED TO MAINTAIN WORKERS EXPOSURE TO ASBESTOS MATERIAL AT OR BELOW THE LIMIT PRESCRIBED IN WAC 296-62-07705
ASBESTOS CEMENT PIPE SHALL BE CUT WITH A HAND OPERATED CARBIDE BLADE CUTTER WITH CONTROLLED FLOWING WATER
CONTAMINATED CLOTHING SHALL BE LEFT AND BURIED IN THE TRENCH OR TRANSPORTED IN SEALED IMPERMEABLE BAGS LABELED IN ACCORDANCE WITH WAC 296-62-07721. AC PIPE SHALL BE LEFT AND BURIED IN THE TRENCH

UNDERMINED AC WATER MAINS

Spanaway Water Company
STANDARD DETAIL 7



SWC VALVE COVER

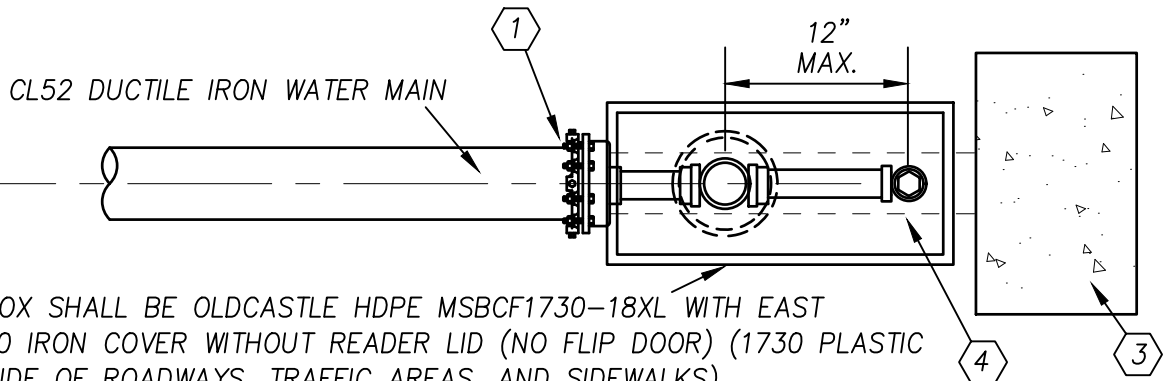

BLOW OFF BOX SHALL BE OLDCASTLE HDPE MSBCF1730-18XL WITH EAST JORDAN 1730 IRON COVER WITHOUT READER LID (NO FLIP DOOR) (1730 PLASTIC COVER OUTSIDE OF ROADWAYS, TRAFFIC AREAS, AND SIDEWALKS) DFW1730CNP-18-BODY (BLACK) W/ DFW1730C-1C_NHK-LID (BLACK)

MAINTAIN 6" (MIN) SEPARATION TOP OF VALVE BOX (SWC COVER) TO BLOW-OFF BOX LID

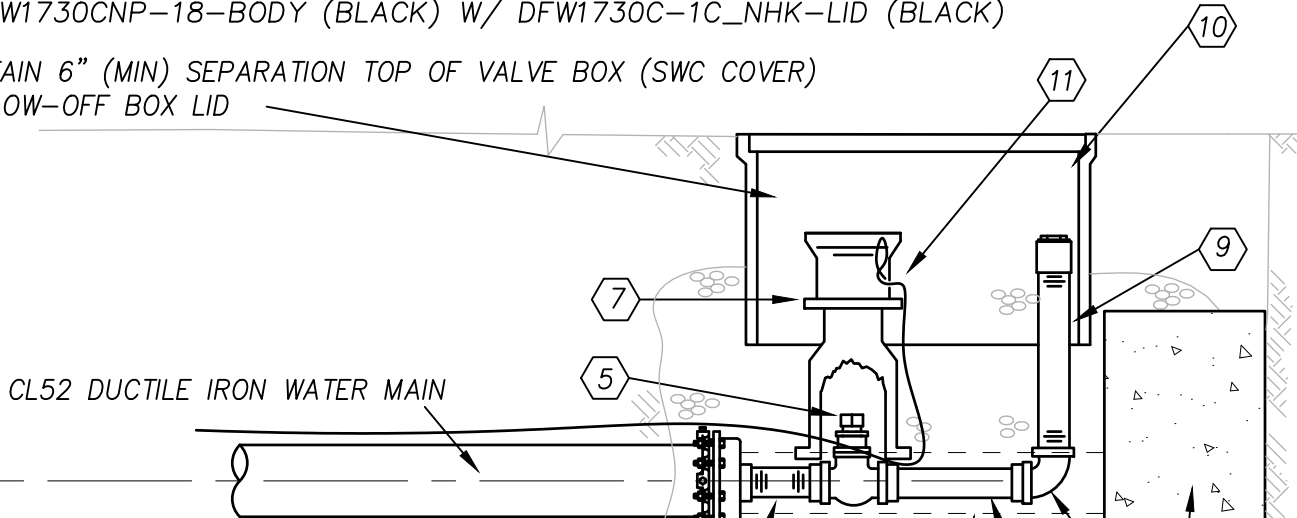

NOTES:

1. MJ END CAP W/2" TAP AND MEGA-LUG
2. 2" X 4" BRASS NIPPLE
- 2A. 2" X 8" BRASS NIPPLE
3. 1/2 ECOLOGY BLOCK (2'X2'X3') - FULL BLOCK (2'X2'X6') FOR 12" DIAMETER PIPE AND ABOVE.
4. SLOTTED LENGTH OF 6" DUCTILE IRON PIPE BUTT FROM END CAP TO 1/2 ECOLOGY BLOCK (ECOLOGY BLOCK SHALL NOT BUTT AGAINST 2" RISER PIPE)
5. 2" BRASS BALL VALVE CURB STOP (FORD BRAND B11-777-NL) WITH 2" OPERATING NUT (QT67)
6. 2" 90° BRASS ELL
7. EJIW CAST IRON VALVE BOX W/ SWC COVER
8. 5/8" CRUSHED GRAVEL, INSIDE AND OUTSIDE BOX TO PREVENT COLLAPSE BACKFILL TO WITHIN 6" OF FINISHED GRADE (MINIMUM)
9. 2" BRASS NIPPLE (LENGTH TO BE DETERMINED)
10. 2" BRASS COUPLING WITH 2" PVC PLUG. PLUG TO BE 'HAND TIGHT'
11. COATED 14 GAUGE (MIN) TRACING WIRE (BLUE COLOR) LOOPED TO FINISH GRADE WITHIN VALVE BOX ASSEMBLY-DRILL HOLE IN RISER TO ENTER BOX

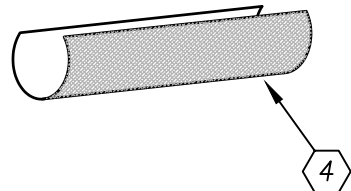

END LINE BLOW OFF ASSEMBLY

Spanaway Water Company
STANDARD DETAIL 8

FLEXIBLE VALVE MARKER POST
 BLUE WITH BLACK STENCILED
 DISTANCE & DIRECTION TO VALVE
 (IF REQUIRED BY WATER COMPANY)



SWC VALVE COVER

PAINT WITH TWO (2) COATS OF
 'PARKER MARATHON' BRAND ENAMEL
 'TAHOE BLUE' No. 1065. PAINT PORTION
 ABOVE GROUND

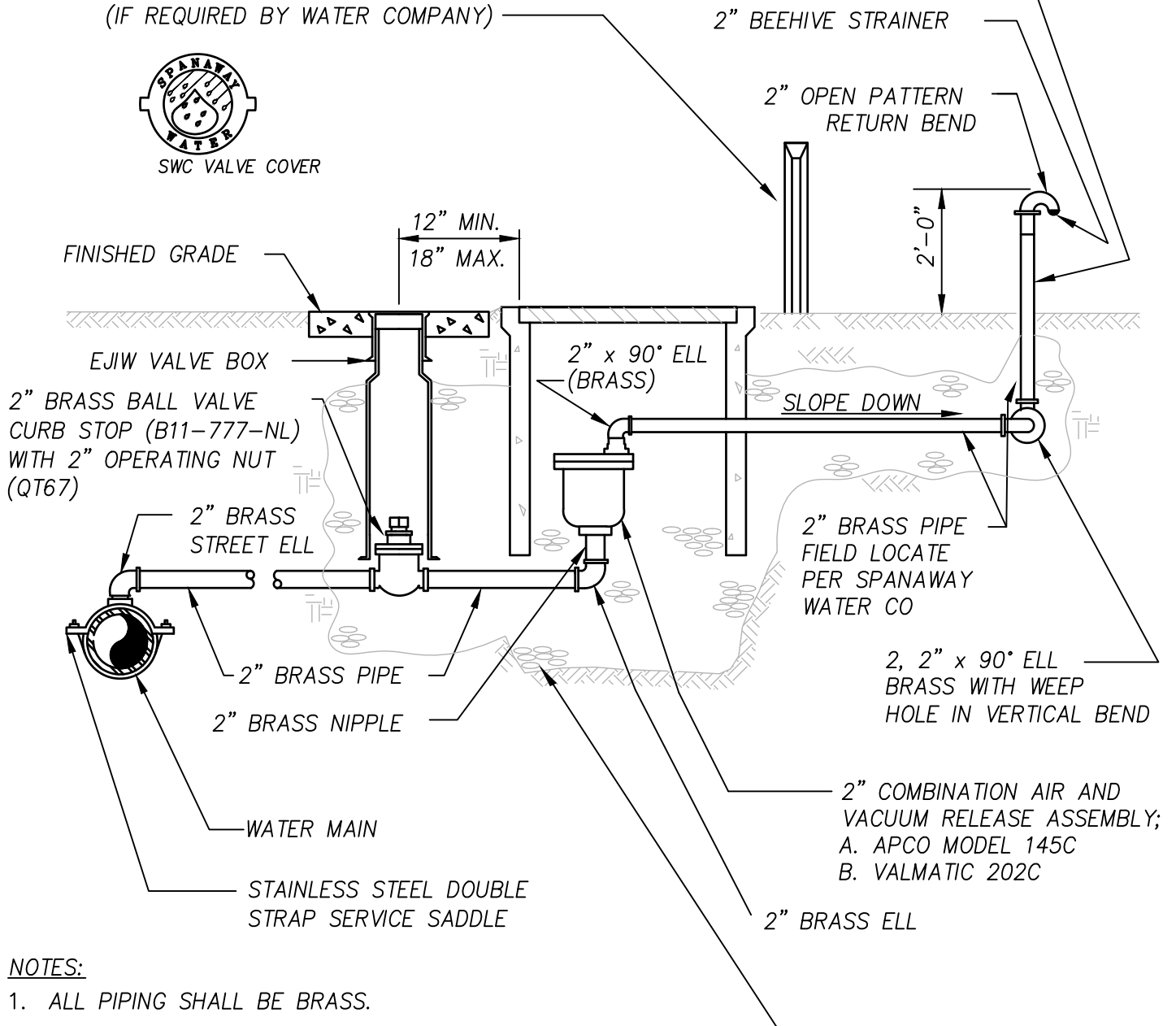

NOTES:

1. ALL PIPING SHALL BE BRASS.
2. TAP WATER MAIN AT HIGH POINT, LOCATION TO BE DETERMINED BY COMPANY.
3. METER BOX SHALL BE HDPE MID-STATES MSBCF1730-18XL WITH MSCBC-1730-R IRON COVERS AND READER LIDS OR DFW1730CNP-18-BODY (BLACK) W/ DFW1730C-1C_NHK-LID (BLACK) (OR APPROVED EQUALS)

5/8" CRUSHED GRAVEL, BACKFILL TO WITHIN 6" OF FINISHED GRADE (MINIMUM).

COMBINATION AIR AND VACUUM RELIEF ASSEMBLY

Spanaway Water Company
 STANDARD DETAIL 9

NOTES:

1. SERVICE FROM STUB TO HOUSE BY PROPERTY OWNER.
2. INDIVIDUAL SERVICES REQUIRED FOR EACH RESIDENTIAL UNIT
3. PROPERTY OWNER MUST CONNECT TO STUB AND NOT SETTER

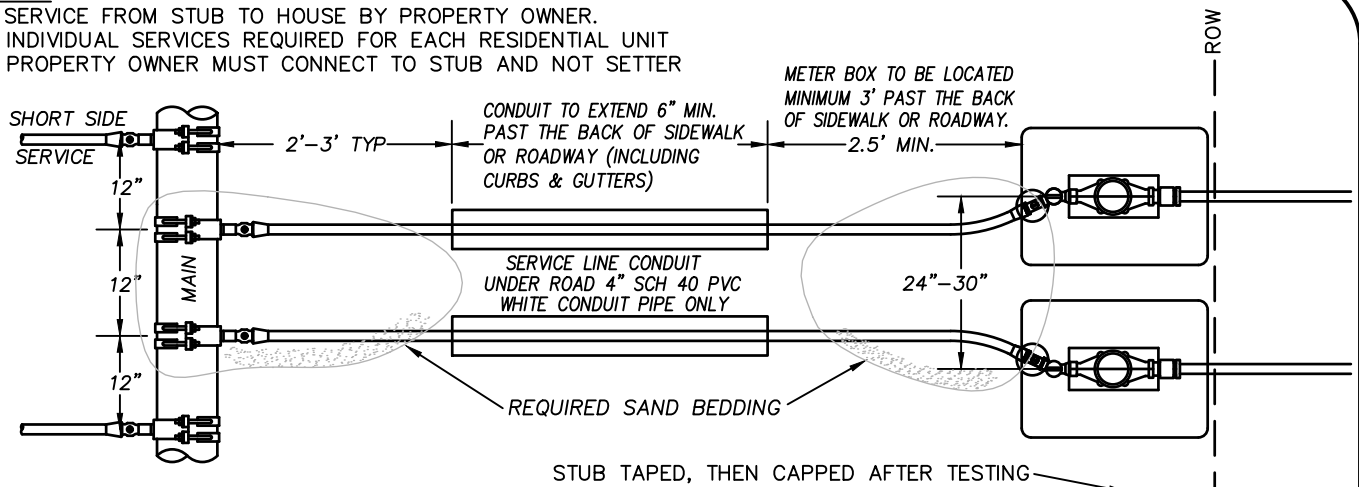

5" CLEARANCE BETWEEN
METER BOX LID AND TOP OF
ANGLE STOP

METER PROVIDED BY SWC AFTER
FINAL PROJECT APPROVAL

RESTORE TO EXISTING OR BETTER
(PER PROJECT SPECIFICATIONS)

NOTE:
CORPORATION STOP AND
CURB STOP TO BE
BEDDED IN SAND

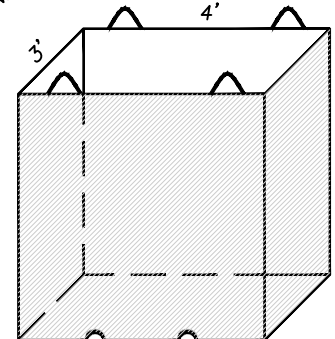
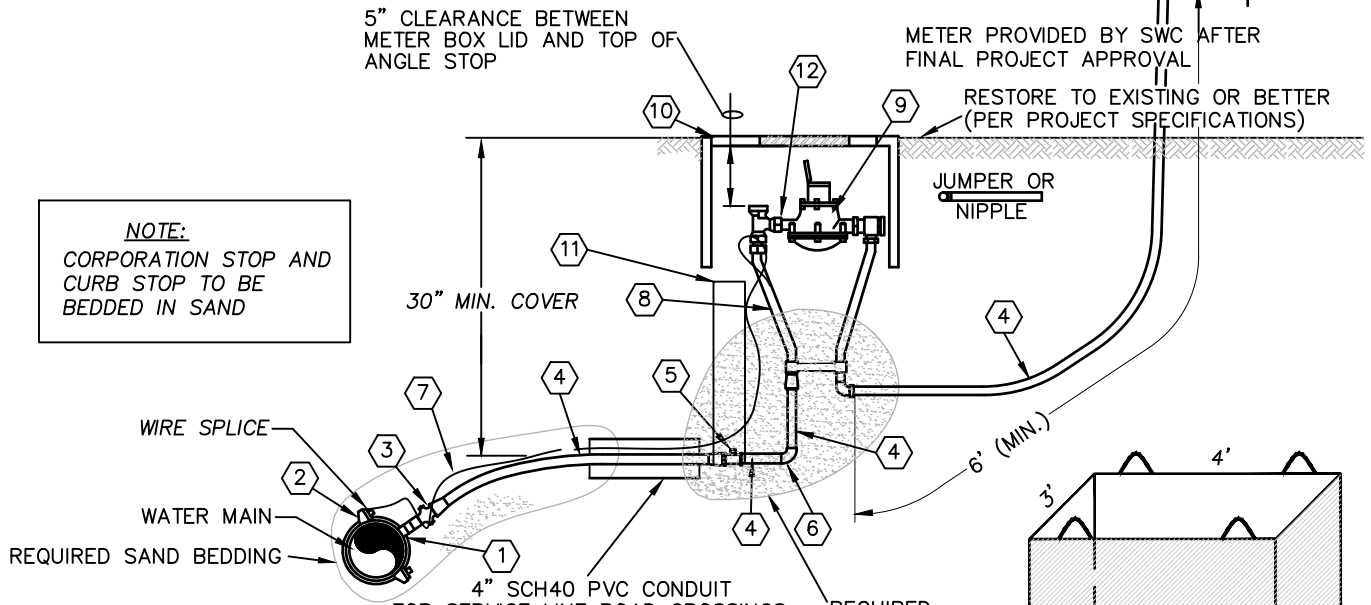

SPANAWAY WATER COMPANY SAND
BEDDING BOX WILL BE MADE
AVAILABLE TO BED AND BACKFILL
ALL RESIDENTIAL AND IRRIGATION
SYSTEM SERVICE STUBS. FILL BOX
WITH SAND FROM CURB STOP TO
6" ABOVE FINISH GRADE.

KEY

- ① 1" TAP
- ② ROMAC SERVICE SADDLES, 202S - PIPE OD - 1" IP (DOUBLE SS BAND)
- ③ FORD CORPORATION STOP FB1101-4-G (1" MIPS X 1" BALL CORP STOP)
- ④ 1" IPS PE 4710 250 PSI POLY PIPE (SIDR 7) TAPED
- ⑤ FORD CURB STOP/BALL VALVE B61-444G (1" FIPS X 1" GRIP)
- ⑥ FORD GRIP COUPLE ELL L-86-44-G (1" MIPS X 1" GRIP COUPLE)
- ⑦ COATED 14 GAUGE (MIN) TRACING WIRE - LEAVE 1' TO 2' WIRE LOOP WITHIN METER BOX
- ⑧ FORD METER SETTER (SERIES VBH72-82-12W-66-44-G-NL)
1" GRIP VERTICAL INLET 1" GRIP HORIZONTAL OUTLET
- ⑨ METER (TO BE PROVIDED BY SPANAWAY WATER COMPANY)
- ⑩ METER BOX - CARSON HW1324-12 OR DFW1324CNP-12-BODY (BLACK)
METER BOX LID - HD1324 W/DI READER LID (WITHOUT INDENTATION)
OR DFW1324C-1C-NHK-LID (BLACK)
- (EAST JORDAN METER BOX LID WITH READER
FOR PAVEMENT OR TRAFFIC AREAS)
- ⑪ INSTALL NOTCHED 4" PVC CONDUIT OVER CURB STOP, CUT
TO JUST BELOW BOTTOM GRADE OF METER BOX AND KEEP
CLEAR OF DEBRIS. INSTALL 4" PVC CAP.
- ⑫ INSTALL JUMPER OR NIPPLE FOR FLUSHING PURPOSES.

NOTE:
STAINLESS STEEL INSERTS REQUIRED ON GRIP
FITTINGS PER MANUFACTURERS SPECIFICATIONS
- #71 3/4 SS INSERT F/IPS PE
- #72 1 SS INSERT F/IPS PE

5/8" X 3/4"
WATER SERVICE CONNECTION

Spanaway Water Company
STANDARD DETAIL 10

NOTES:

1. SERVICE FROM STUB TO HOUSE BY PROPERTY OWNER.
2. INDIVIDUAL SERVICES REQUIRED FOR EACH RESIDENTIAL UNIT
3. PROPERTY OWNER MUST CONNECT TO STUB AND NOT SETTER

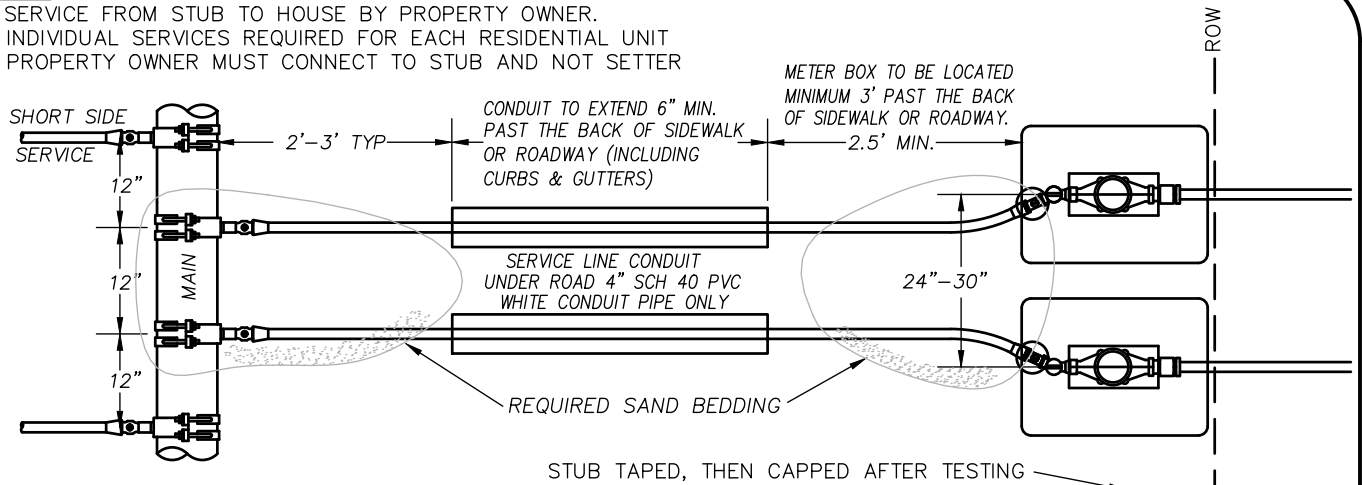

5" CLEARANCE BETWEEN METER BOX LID AND TOP OF ANGLE STOP

METER PROVIDED BY SWC AFTER FINAL PROJECT APPROVAL

RESTORE TO EXISTING OR BETTER (PER PROJECT SPECIFICATIONS)

NOTE:
CORPORATION STOP AND CURB STOP TO BE BEDDED IN SAND

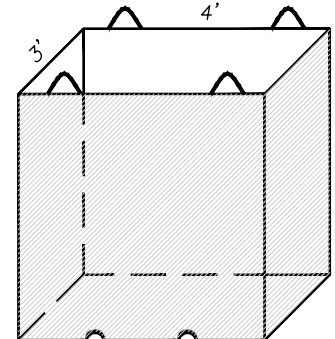
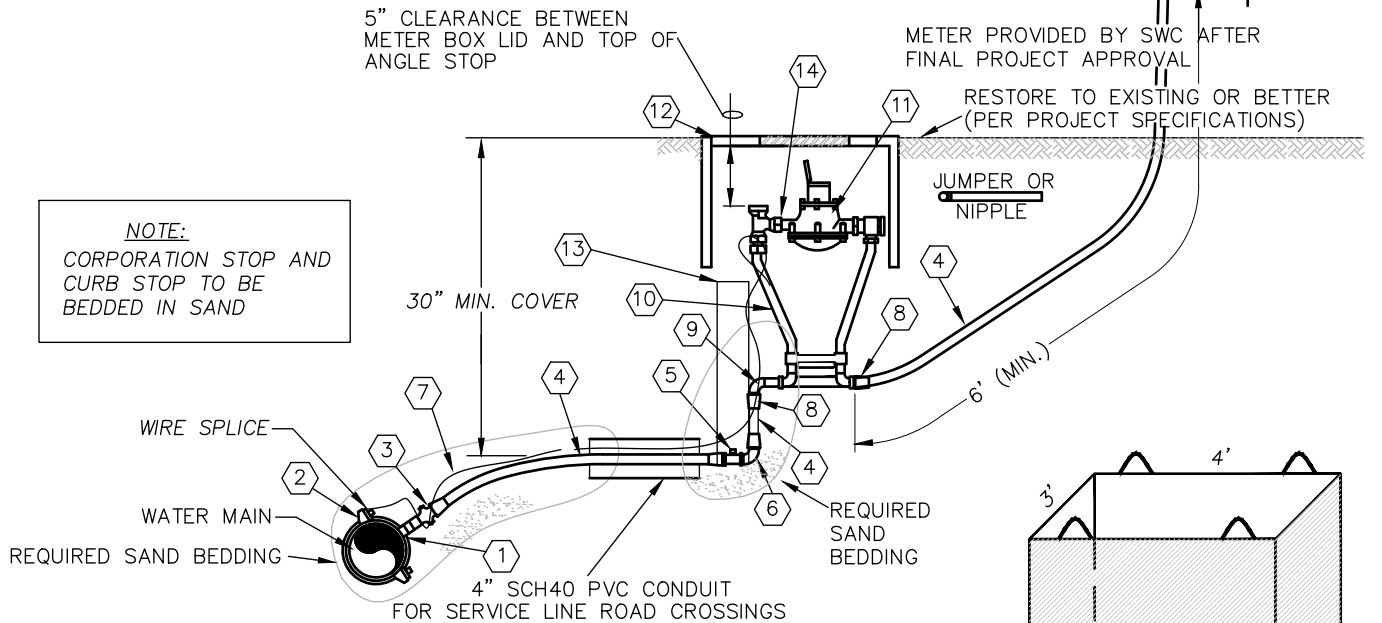

SPANAWAY WATER COMPANY SAND BEDDING BOX WILL BE MADE AVAILABLE TO BED AND BACKFILL ALL RESIDENTIAL AND IRRIGATION SYSTEM SERVICE STUBS. FILL BOX WITH SAND FROM CURB STOP TO 6" ABOVE FINISH GRADE.

KEY

- ① 1" TAP
- ② ROMAC SERVICE SADDLES, 202S - PIPE OD - 1" IP (DOUBLE SS BAND)
- ③ FORD CORPORATION STOP FB1101-4-G (1" MIPS X 1" BALL CORP STOP)
- ④ 1" IPS PE 4710 250 PSI POLY PIPE (SIDR 7) TAPED
- ⑤ FORD CURB STOP/BALL VALVE B61-444G (1" FIPS X 1" GRIP)
- ⑥ FORD GRIP COUPLE ELL L-86-44-G (1" MIPS X 1" GRIP COUPLE)
- ⑦ COATED 14 GAUGE (MIN) TRACING WIRE - LEAVE 1' TO 2' WIRE LOOP WITHIN METER BOX
- ⑧ FORD ADAPTOR COUPLING L86-44-G (1" MIPS X 1" GRIP COUPLING)
- ⑨ 1" ST. ELL - BRASS
- ⑩ FORD METER SETTER (SERIES VBH74-12W-11-44) 1" WITH DOUBLE PURPOSE COUPLINGS, LOCK WINGS
- ⑪ METER (TO BE PROVIDED BY SPANAWAY WATER COMPANY)
- ⑫ METER BOX - CARSON HW1324-12 OR DFW1324CNP-12-BODY (BLACK)
METER BOX LID - HD1324 W/DI READER LID (WITHOUT INDENTATION)
OR DFW1324C-1C-NHK-LID (BLACK)

- ⑬ INSTALL NOTCHED 4" PVC CONDUIT OVER CURB STOP, CUT TO JUST BELOW BOTTOM GRADE OF METER BOX AND KEEP CLEAR OF DEBRIS. INSTALL 4" PVC CAP.
- ⑭ INSTALL JUMPER OR NIPPLE FOR FLUSHING PURPOSES.

(EAST JORDAN METER BOX LID WITH READER FOR PAVEMENT OR TRAFFIC AREAS)

NOTE:
STAINLESS STEEL INSERTS REQUIRED ON GRIP FITTINGS PER MANUFACTURERS SPECIFICATIONS
- #71 3/4 SS INSERT F/IPS PE
- #72 1 SS INSERT F/IPS PE

1" WATER SERVICE CONNECTION
Spanaway Water Company
STANDARD DETAIL 11

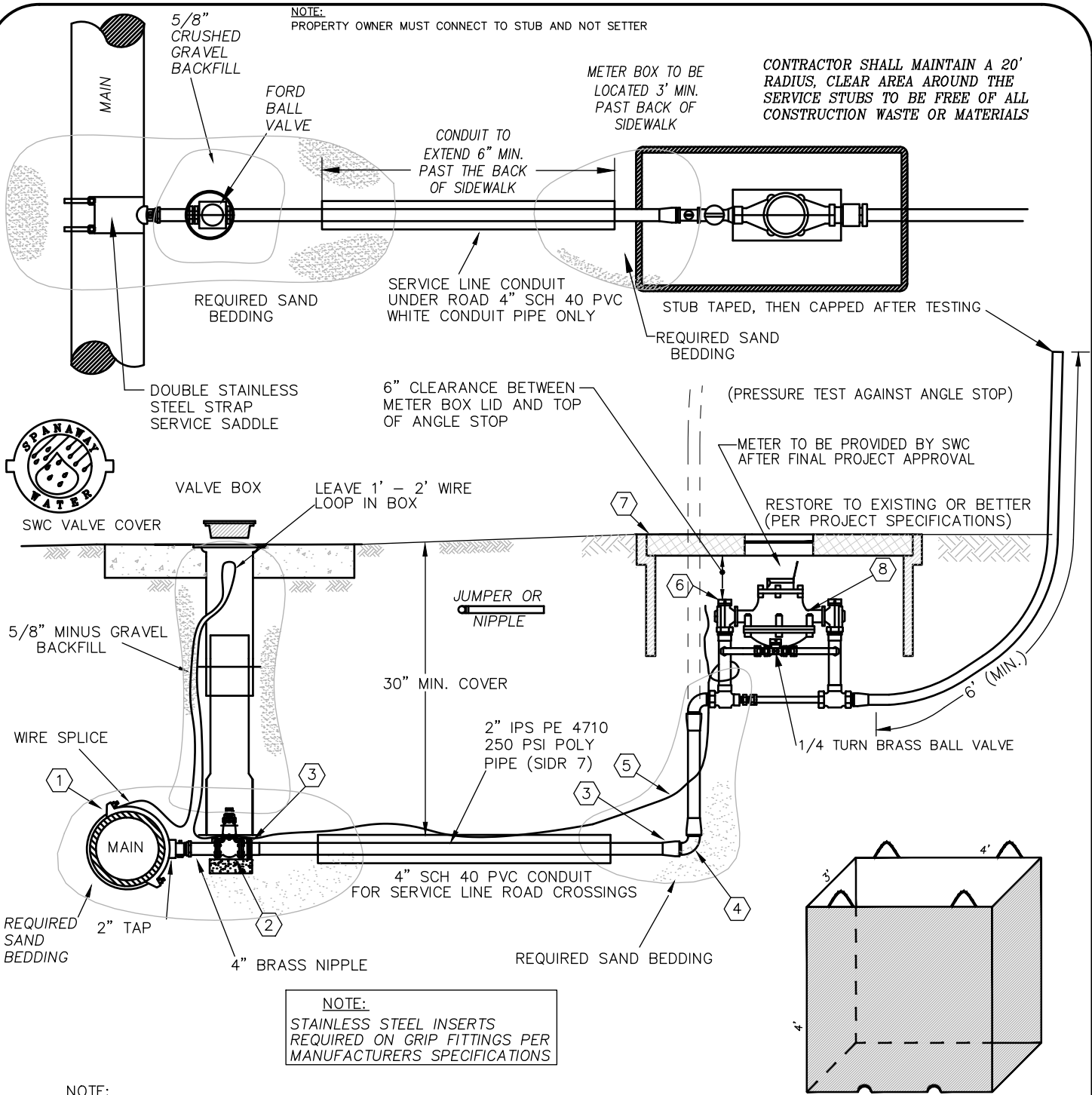

KEY

- ① ROMAC SERVICE SADDLE, 202S - PIPE OD - 2" IP (DOUBLE SS BAND)
- ② FORD BRASS BALL VALVE (W/GATE VALVE OPERATING NUT 1.5") B11-777 (W/QT67)
- ③ FORD ADAPTER/COUPLING C8477G/C1477G (2" GRIP COUPLE x 2" MCTS)
- ④ FORD GRIP COUPLE ELL L-84-77-G (2" MCTS X 2" GRIP COUPLE OR 2" BRASS ST ELL & C84-77-G
- ⑤ COATED 14 GAUGE (MIN) TRACING WIRE - THROUGH CONDUIT, WRAPPED AROUND THE SETTER INLET AND CONNECTED TO WIRE ON MAIN.
- ⑥ FORD METER SETTER (HORIZONTAL INLET/OUTLET) VBH76-12HB-11-77-NL
- ⑥ FORD METER SETTER (VERTICAL INLET/OUTLET) VBH86-12HB-11-77-NL
- ⑦ METER BOX CARSON HW1730-18; DFW1730CNP-18-BODY (BLACK); METER BOX LID CARSON HD1730; DFW1730C-1C_NHK-LID (BLACK) - METER BOX LID FOR TRAFFIC APPLICATION - EAST JORDAN TRAFFIC LID (SOLID LID NO READER)
- ⑧ JUMPER OR NIPPLE INSTALLED FOR FLUSHING PURPOSES

SPANAWAY WATER COMPANY SAND BEDDING BOX TO BE USED TO BED AND BACKFILL ALL RESIDENTIAL AND IRRIGATION SYSTEM SERVICE STUBS. FILL BOX WITH SAND FROM CURB STOP TO FINISH GRADE

2" WATER SERVICE CONNECTION

**Spanaway Water Company
STANDARD DETAIL 13**

CONCRETE PAD WILL BE REQUIRED FOR VALVES AND VALVE CLUSTERS

VALVE BOX AND SWC LID FLUSH WITH GRADE IN ASPHALT AREAS (PAINTED BLUE)

2" MIN. CLASS "B" ASPHALT PATCH (PATCH OVER CONCRETE COLLAR)

18" DIAMETER CONCRETE COLLAR (6" MINIMUM DEPTH)

EXISTING ASPHALT

ALIGN 'EARS' ON LID WITH DIRECTION OF MAIN LINE

VALVE BOX CENTERED OVER OPERATING NUT

VALVE

5/8" CRUSHED GRAVEL 95% COMPACTION

BLUE COATED 14 GAUGE (MIN) TRACING WIRE 3M DIRECT BURY SPLICE KIT 09964 DRILL HOLE TO ENTER BOX PROVIDE 1' TO 2' LOOPED IN VALVE BOX NEAR FINISH GRADE

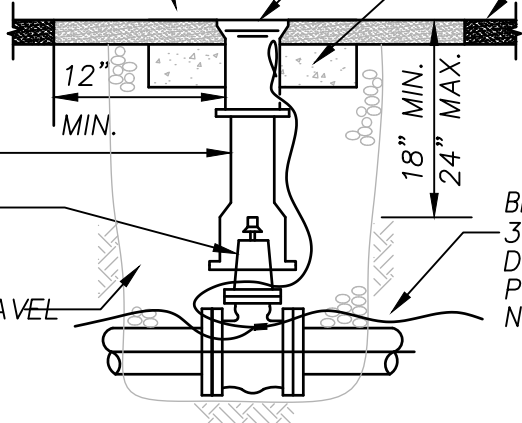

NOTE: ROAD CROSSINGS MUST MEET THE MOST CURRENT REQUIREMENTS OF THE LOCAL GOVERNING JURISDICTION.

VALVE BOX IN OR ADJACENT TO EXISTING ASPHALT AREA



SWC VALVE COVER

VALVE BOX AND LID FLUSH WITH GRADE (PAINTED BLUE)

3' DIAMETER CONCRETE COLLAR (6" MINIMUM DEPTH)

ALIGN 'EARS' ON LID WITH DIRECTION OF MAIN LINE

FINISHED GRADE

VALVE BOX CENTERED OVER OPERATING NUT

VALVE

BLUE COATED 14 GAUGE (MIN) TRACING WIRE 3M DIRECT BURY SPLICE KIT 09964 DRILL HOLE TO ENTER BOX PROVIDE 1' TO 2' LOOPED IN VALVE BOX NEAR FINISH GRADE

5/8" CRUSHED, COMPACTED GRAVEL, BACKFILL TO WITHIN 6" OF FINISHED GRADE (MINIMUM).

NOTE: EACH VALVE SHALL BE PROVIDED WITH AN ADJUSTABLE 'EAST JORDAN IRON WORKS' VALVE BOX AND SWC LOGO COVER
VALVE BOXES SHALL NOT DIRECTLY CONTACT OR REST ON THE VALVE ASSEMBLY

VALVE BOX IN UNIMPROVED AREA

3' DIAMETER CONCRETE COLLAR MAY BE REQUIRED WITHIN UNIMPROVED AREAS, AS SHOWN ON DESIGN DRAWING OR DESIGN SCHEMATIC

VALVE BOX

VALVE BOX TOP: EAST JORDAN 00366918
24" VALVE BOX BOTTOM: EAST JORDAN 855524B
36" VALVE BOX BOTTOM: EAST JORDAN 855536B

Spanaway Water Company
STANDARD DETAIL 14



SWC VALVE COVER

FINISHED GRADE

VALVE BOX AND SWC LID FLUSH WITH GRADE IN ASPHALT AREAS, PAINTED BLUE (SEE DETAIL 14)

42" MAX. BURY BEFORE EXTENSION STEM IS REQUIRED

12" MIN.

24" MAX

VARIABLE

CAST IRON VALVE BOX (SEE STANDARD DETAIL #14)

2" SQUARE OPERATING NUT

CENTERING PLATE

EXTENSION STEM (LENGTH VARIES)

2" FEMALE SOCKET COUPLING C.I. ASTM 126 C30 (OR SWC APPROVED EQUAL)

BLUE COATED 14 GAUGE (MIN) TRACING WIRE 3M DIRECT BURY SPLICE KIT 09964 DRILL HOLE TO ENTER BOX PROVIDE 1' TO 2' LOOPED IN VALVE BOX NEAR FINISH GRADE

5/8" CRUSHED, COMPACTED GRAVEL, BACKFILL TO WITHIN 6" OF FINISHED GRADE (MINIMUM).

PROVIDE CONCRETE COLLAR (WITHIN PAVED AREA) OR CONCRETE PAD (UNIMPROVED AREA) AS SHOWN ON SWC STANDARD DETAIL #14

NOTE:

EACH VALVE SHALL BE PROVIDED WITH AN ADJUSTABLE CAST IRON VALVE BOX AND LID, 940 AND 940 B VALVE BOXES SHALL NOT DIRECTLY CONTACT OR REST ON THE VALVE ASSEMBLY

VALVE EXTENSION STEM

Spanaway Water Company
STANDARD DETAIL 15

TYPE "A" BLOCKING FOR 11 1/4°-22 1/2° VERTICAL BENDS						
PIPE SIZE NOMINAL DIAMETER - INCHES	TEST PRESSURE PSI	VB VERTICAL BEND DEGREES	No. OF CU. FT. OF CONC. BLOCKING	S SIDE OF CUBE LIN. FT.	D DIAM. OF SHACKLE RODS (2) INCHES	L DEPTH OF RODS IN CONCRETE LIN. FT.
4"	250	11 1/4	8	2	5/8"	1.5
		22 1/2	11	2.2		2.0
6"	250	11 1/4	11	2.2	5/8"	2.0
		22 1/2	25	2.9		
8"	250	11 1/4	16	2.5	5/8"	2.0
		22 1/2	47	3.6		
12"	250	11 1/4	64	4	1"	2.0
		22 1/2	125	5	1"	3.0
16"	250	11 1/4	70	4.1	7/8"	3.0
		22 1/2	184	5.7	1 1/8"	4.0

TYPE "B" BLOCKING FOR - 45° VERTICAL BENDS						
		VB		S	D	L
4"	250	45	30	3.1	5/8"	2.0
6"			68	4.1		
8"			123	5.0		
12"	250		232	6.1	3/4"	2.5
16"	250		478	7.8	1 1/8"	4.0

THE APPLICATION OF ALTERNATIVE METHODS OR MATERIALS WILL BE DETERMINED BY SWC'S ENGINEER ON A CASE BY CASE BASIS

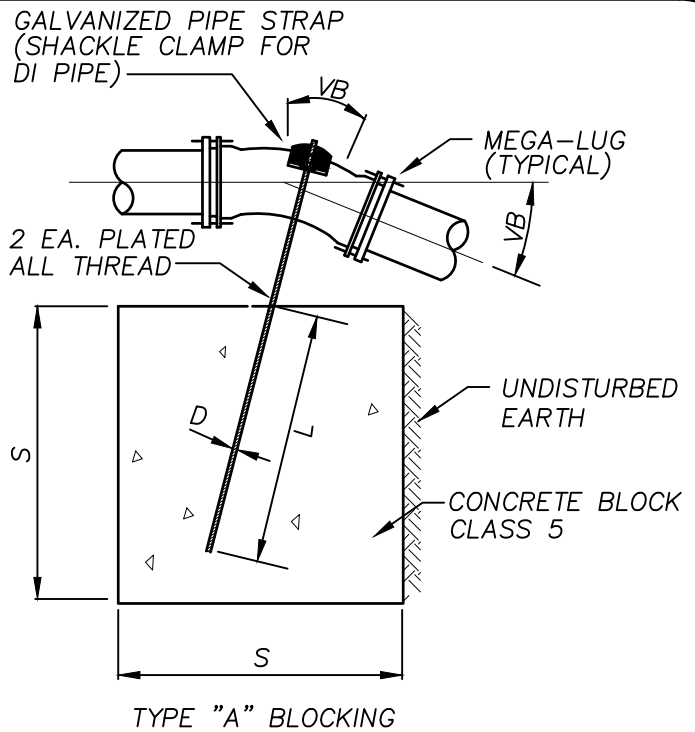

ALL CONCRETE SHALL HAVE A STRENGTH OF NOT LESS THAN 1800 PSI AT SEVEN DAYS AND 3000 PSI AT 28 DAYS.

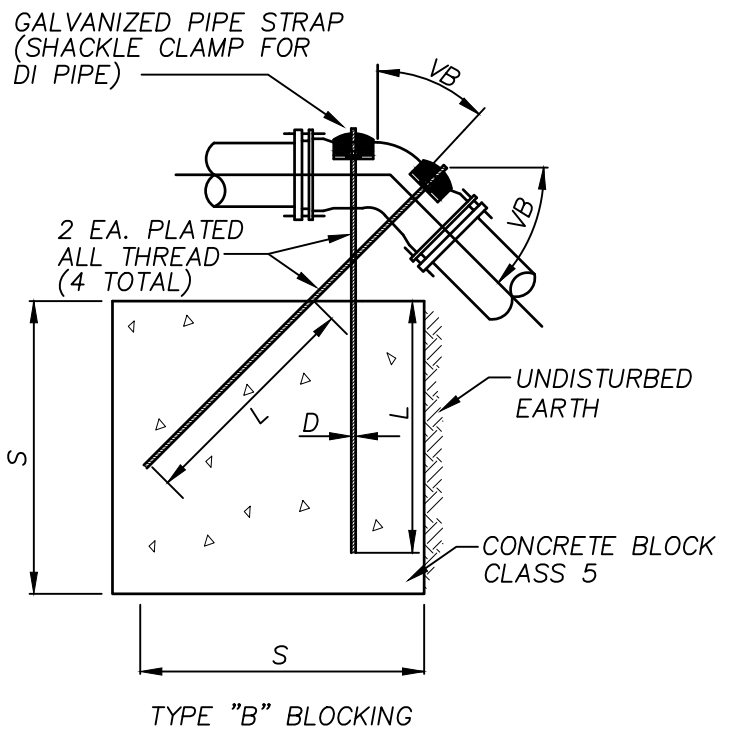

VERTICAL ANCHOR BLOCK

Spanaway Water Company
STANDARD DETAIL 16

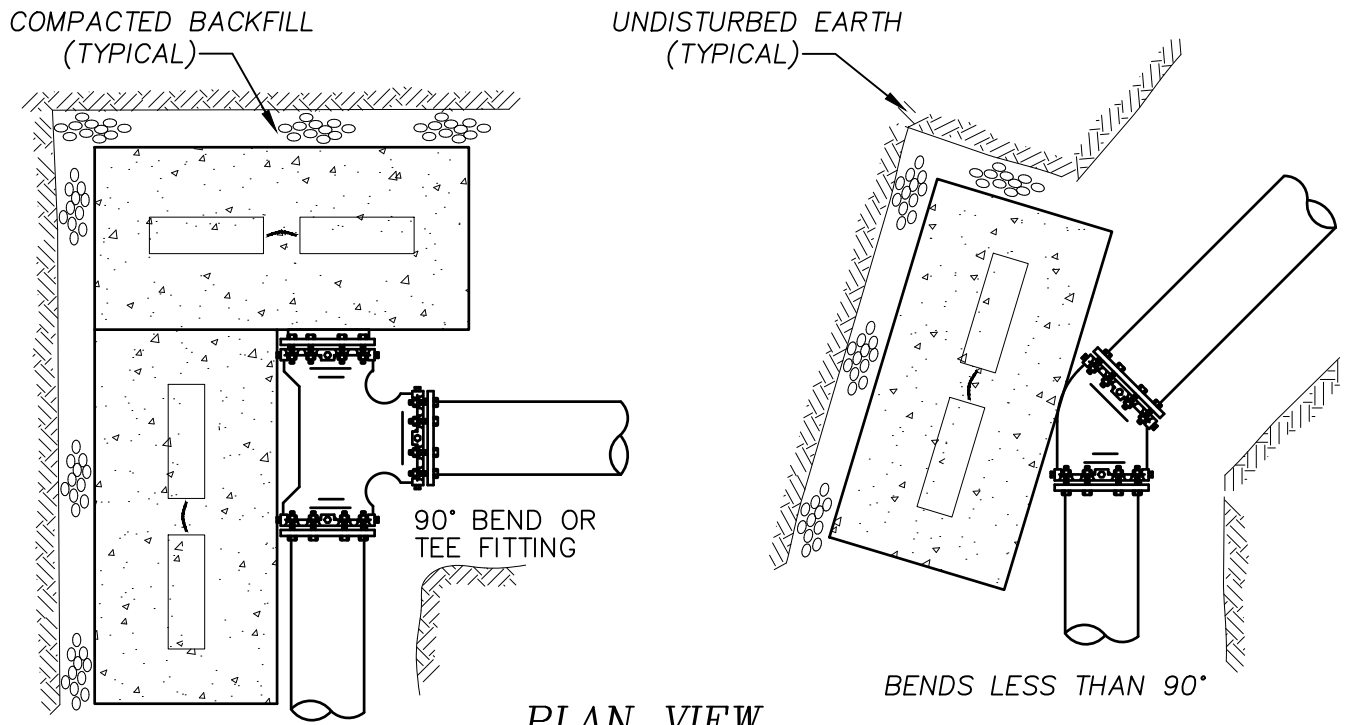

PLAN VIEW

MANUFACTURED ECOLOGY BLOCK (OR APPROVED EQUAL) SHALL BE USED IN LIEU OF POURED BLOCKS FOR ALL SWC WATER MAIN CONSTRUCTION (UNLESS OTHERWISE SPECIFIED BY THE ENGINEER)

1/2 ECOLOGY BLOCKS (2' X 2' X 3') SHALL BE USED FOR MAINS 12" DIA AND SMALLER (UNLESS OTHERWISE SPECIFIED BY THE ENGINEER)

FULL ECOLOGY BLOCKS (2' X 2' X 6') WILL BE USED FOR 16" DIA MAINS (MAINS GREATER THAN 16" SHALL BE PROJECT SPECIFIC - PER THE ENGINEER)

BLOCKS SHALL BE PLACED ON LEVEL GROUND, BUTT AGAINST FITTING, WITH COMPACTED BACKFILL BETWEEN BACK OF BLOCK AND UNDISTURBED SOIL

ALL MJ FITTINGS SHALL USE 'MEGA-LUG' RESTRAINTS

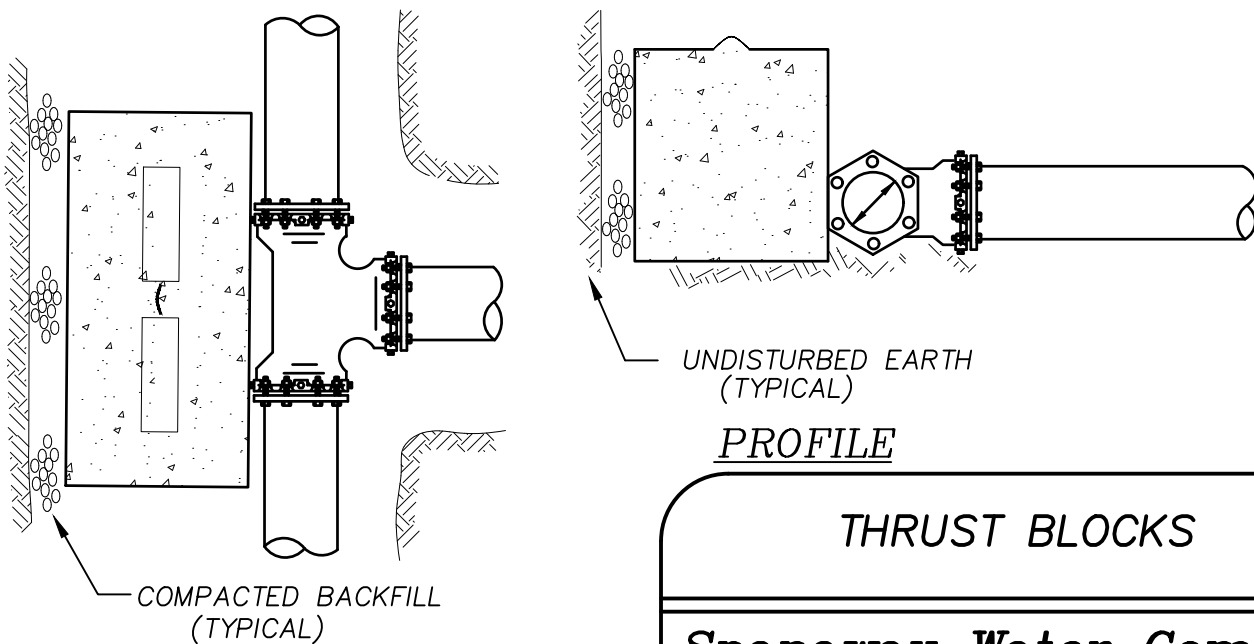

PROFILE

THRUST BLOCKS

Spanaway Water Company
STANDARD DETAIL 17

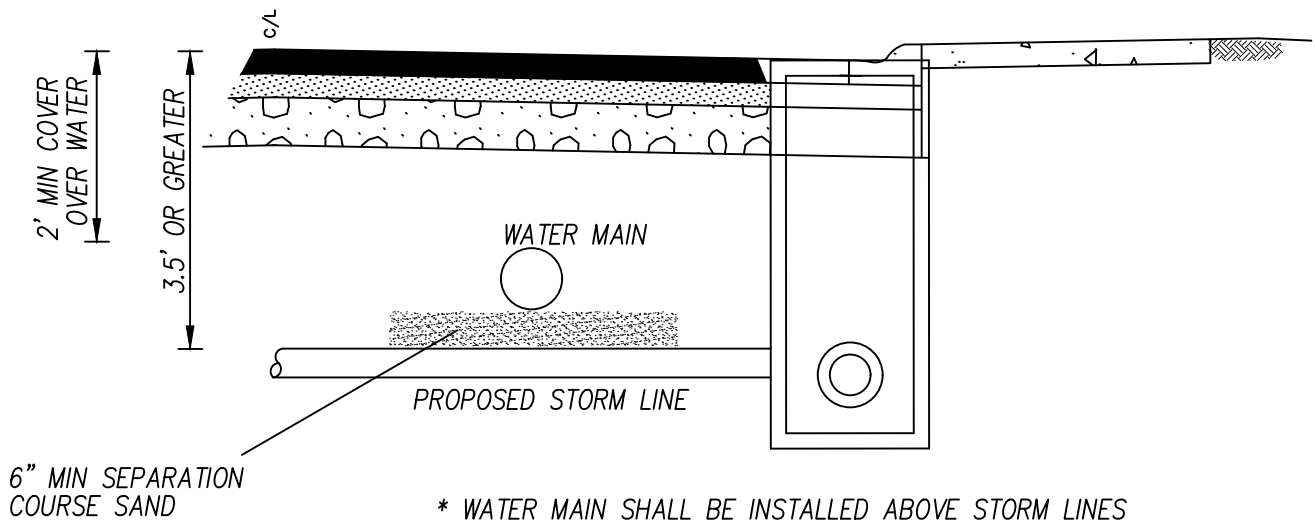

* WATER MAIN SHALL BE INSTALLED ABOVE STORM LINES
 CONSTRUCTED WITH COVER OF 3.5' OR GREATER. MAINTAIN
 6" SAND SEPARATION BETWEEN WATER AND STORM MAINS

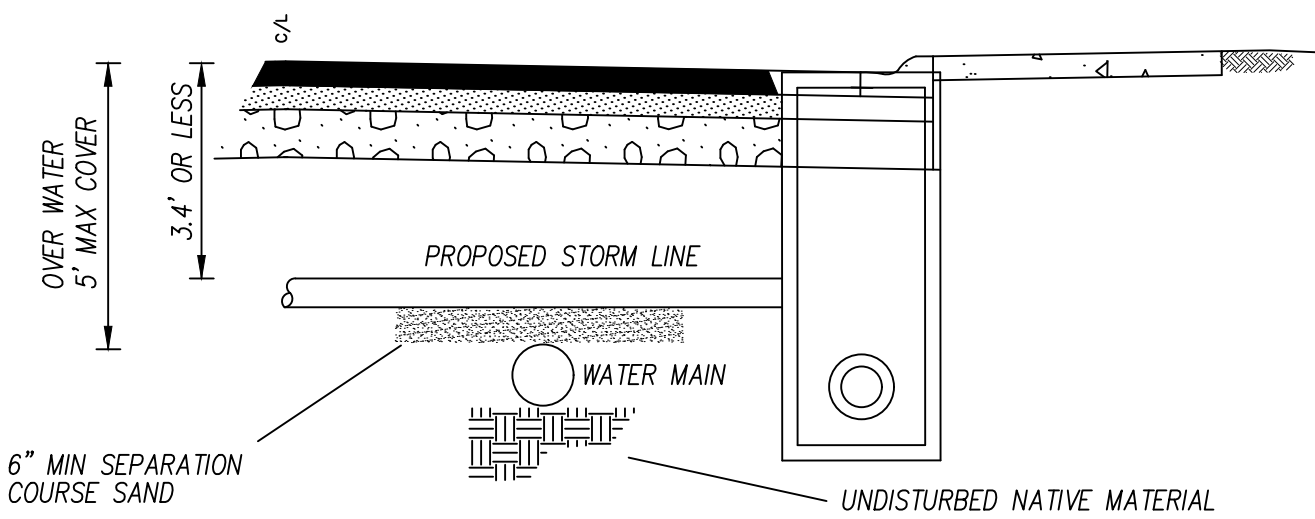

6" MIN SEPARATION COURSE SAND

UNDISTURBED NATIVE MATERIAL
 PROVIDE LEVEL PIPE BEDDING
 (ROCKS OVER 2" REMOVED)

* WATER MAIN SHALL BE INSTALLED BELOW STORM LINES
 CONSTRUCTED WITH COVER OF 3.4' OR LESS. MAINTAIN 6"
 SAND SEPARATION BETWEEN WATER AND STORM MAINS

TYPICAL STORM CROSSING

N.T.S.

ALL CONSTRUCTED WATER MAINS SHALL HAVE A 36" MINIMUM TO A 42" MAXIMUM COVER FROM THE CROWN OF THE PIPE. THE COVER DEPICTED ABOVE SHALL ONLY BE ALLOWED UNDER SPECIAL CIRCUMSTANCE FOLLOWING SWC MANAGEMENT REVIEW AND APPROVAL.

**TYPICAL UTILITY CROSSING
 (STORM)**

Spanaway Water Company
 STANDARD DETAIL 18

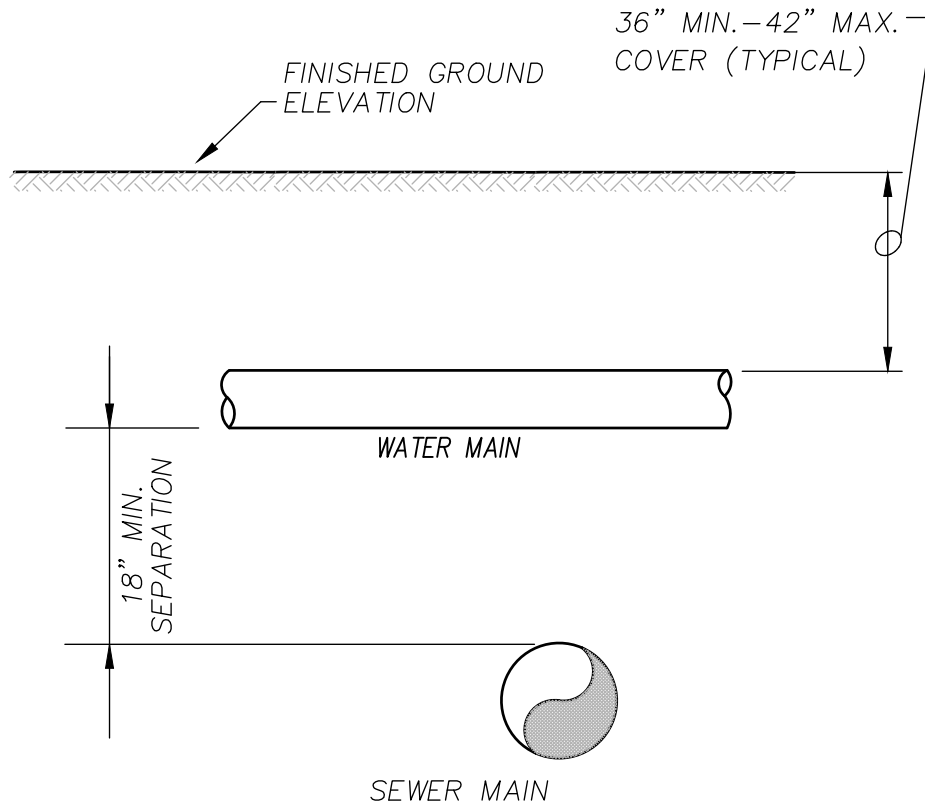

HORIZONTAL AND VERTICAL SEPARATION BETWEEN WATER AND SANITARY SEWER MAINS AND SEWER LATERALS SHALL BE PER PIERCE COUNTY PUBLIC WORKS REQUIREMENTS. MAINTAIN A MINIMUM HORIZONTAL SEPARATION OF 10 FEET BETWEEN WATER LINES AND ANY EXISTING OR NEW SANITARY SEWERS. THE DISTANCE SHALL BE MEASURED EDGE TO EDGE FROM OUTER DIAMETER OF THE PIPES.

REQUIRED VERTICAL SEPARATION FOR WATER LINES IS 18" MINIMUM ABOVE THE SEWER LINE (SEPARATION SHALL BE MEASURED FROM THE OUTER WALL OF THE PIPES).

TYPICAL UTILITY CROSSING
(SEWER)

Spanaway Water Company
STANDARD DETAIL 19

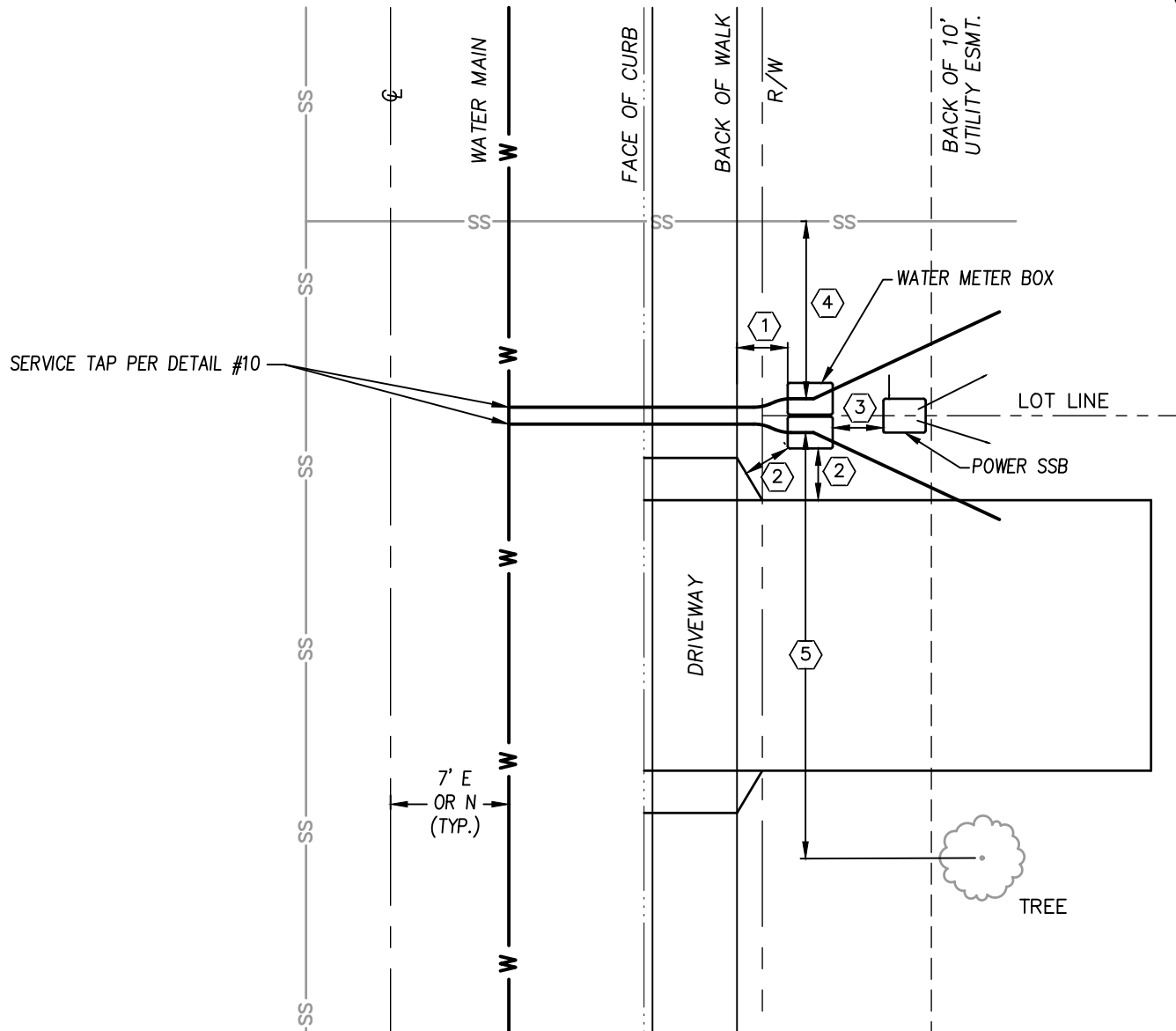

NOTES:

- ① WATER METER BOX TO BE LOCATED IN SOFT SURFACE/LANDSCAPING, AND SHALL BE 3' MIN FROM SIDEWALK.
- ② WATER METER BOX TO BE 3' MIN FROM DRIVEWAY.
- ③ WATER METER BOXES TO BE 3' MIN FROM POWER BOXES OR TRANSFORMERS.
- ④ WATER SERVICE LINE TO BE 10' MIN FROM SANITARY SEWER SERVICE.
- ⑤ WATER SERVICE LINE TO BE 10' MIN FROM TREES.

**CLEARANCES FOR TYPICAL
WATER SERVICES**

**Spanaway Water Company
STANDARD DETAIL 20**

10' UTILITY EASEMENT

10' UTILITY EASEMENT

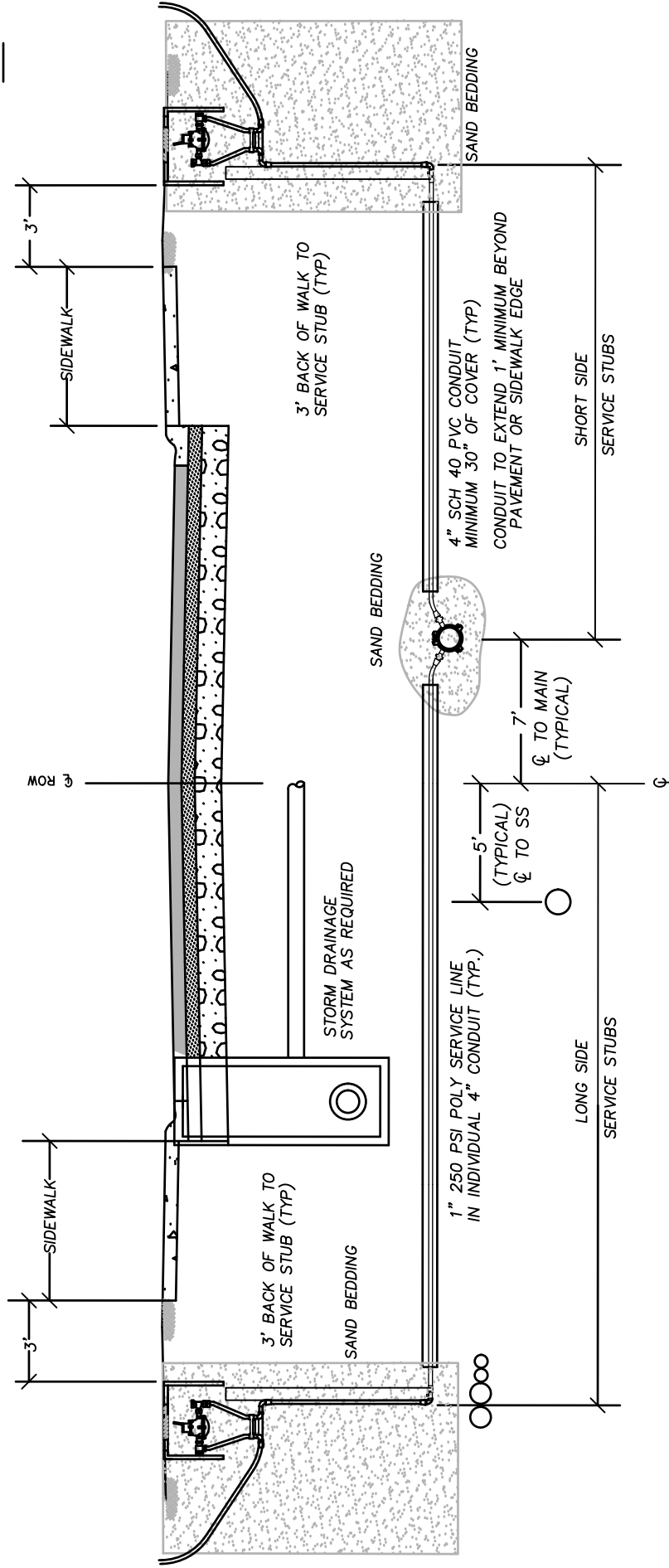

WATER SERVICE LINES TO BE LOCATED ABOVE ALL JOINT TRENCH UTILITY LINES AND CONDUIT

ROAD AND UTILITIES TRACT/EASEMENT TYPICAL ROADWAY CROSS-SECTION

NTS (THIS DETAIL FOR WATER SYSTEM FACILITIES LOCATION ONLY)

TYPICAL ROAD CROSS SECTION

Spanaway Water Company
STANDARD DETAIL 21

REDUCED PRESSURE BACKFLOW ASSEMBLY (RPBA AND RPDA)

Spanaway Water Company STANDARD DETAIL 22

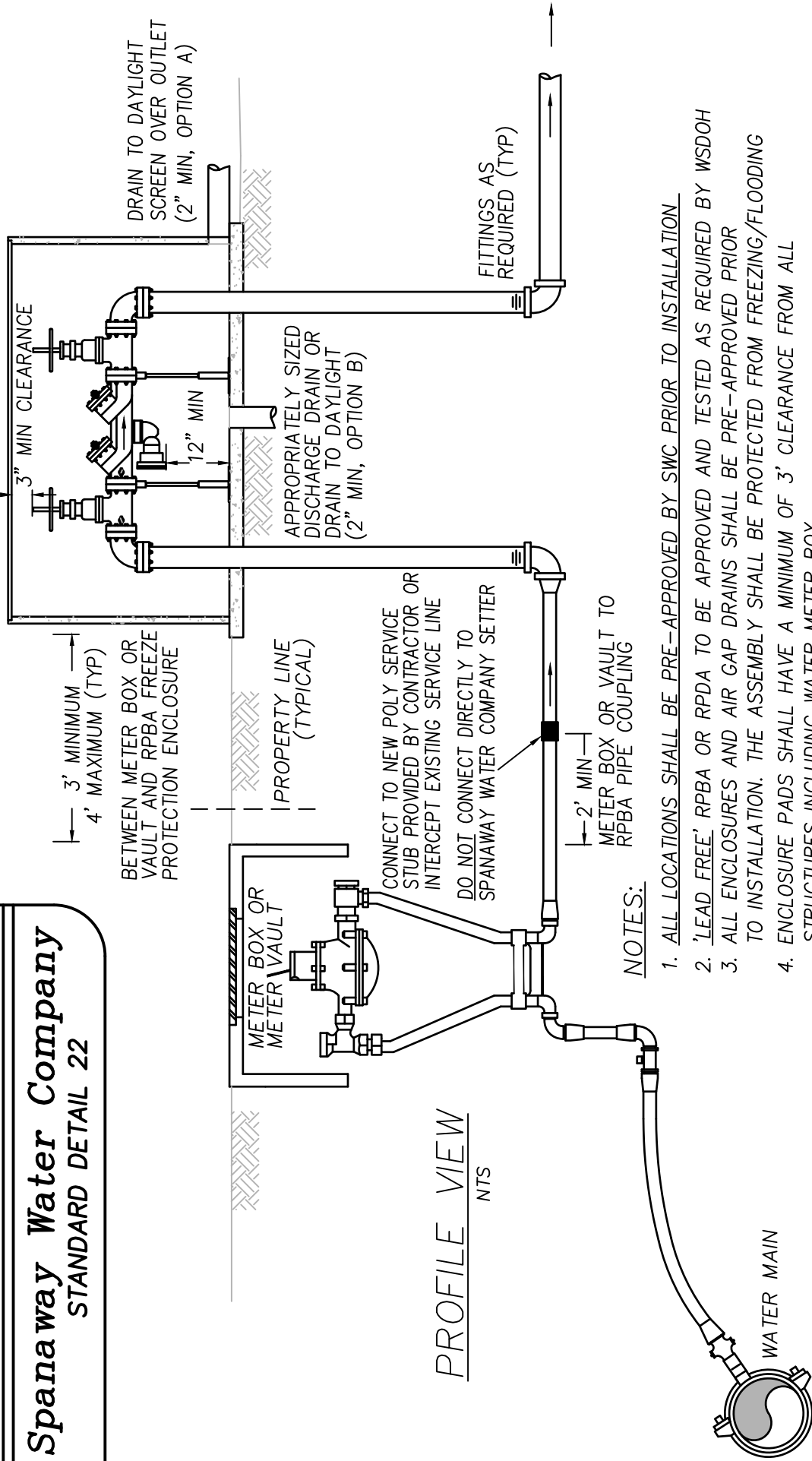

PROFILE VIEW

NTS

NOTES:

1. ALL LOCATIONS SHALL BE PRE-APPROVED BY SWC PRIOR TO INSTALLATION
2. 'LEAD FREE' RPBA OR RPDA TO BE APPROVED AND TESTED AS REQUIRED BY WSDOH
3. ALL ENCLOSURES AND AIR GAP DRAINS SHALL BE PRE-APPROVED PRIOR TO INSTALLATION. THE ASSEMBLY SHALL BE PROTECTED FROM FREEZING/FLOODING
4. ENCLOSURE PADS SHALL HAVE A MINIMUM OF 3' CLEARANCE FROM ALL STRUCTURES INCLUDING WATER METER BOX
5. THE BACKFLOW ASSEMBLY SHALL BE TESTED AFTER INSTALLATION AND PRIOR TO ACCEPTANCE. SPANAWAY WATER COMPANY PERSONNEL SHALL INSPECT THE INSTALLATION FOR APPROVAL. TESTING WILL BE REQUIRED ON AN ANNUAL BASIS PER STATE DOH AND SPANAWAY WATER COMPANY REQUIREMENTS.

REFER TO SPANAWAY WATER COMPANY STANDARDS REGARDING STATE APPROVED CROSS CONNECTION CONTROL DEVICES, WATER COMPANY INITIAL ACCEPTANCE, AND ANNUAL TESTING REQUIREMENTS

SPANAWAY WATER COMPANY, Inc.
18413 'B' Street East
Spanaway, Washington 98387-4619
(253) 531-9024

CONSTRUCTION WATER USE AGREEMENT
WATER TRUCK AUTHORIZATION

All construction water tank trucks (road cleaning, dust control, compaction, hydroseeding, etc.) shall only be filled from the designated connection located at the Spanaway Water Company (SWC) main office and shall only be allowed under this agreement and contract with SWC. All tanks or vessels shall have approved cross connection control, preferably an approved air gap. Cross connection control must be approved by SWC personnel. All Contractor vehicles must be inspected, or show SWC prior approval based on an earlier inspection, prior to any filling. On-site construction water will only be allowed under special arrangement and contract with Spanaway Water Company. Water from tank trucks is non-potable and is therefore forbidden from use in or around water infrastructure. This includes pressure testing, cleaning water pipe, and AC dust suppression. Refer to the 'ON-SITE HYDRANT METER USE AUTHORIZATION' for on-site construction water. The unauthorized use of water will result in the following penalties;

- 1) First offense will result in a written warning
- 2) Second offense will result in \$500 fine and notification to Pierce County Sheriff department regarding theft of water
- 3) Third offense will result in \$1,000 fine, notification to Pierce County Sheriff department regarding theft of water; further use of water from Spanaway Water Company shall be prohibited.
- 4) Outstanding fines will prevent final water system approval and acceptance (new construction)

CROSS CONNECTION INSPECTION

VEHICLE PERMIT:

_____, as representative for:

Printed name of signer

Name of company

Company billing address

Company office address

City,

State

Zip Code

(_____) _____
Phone number

Spanaway Water Company grants cross connection inspection approval for the following vehicle;

Vehicle Make

Model

License Number

A signed copy of this permit shall be kept in the inspected vehicle at all times, to be made available to Spanaway Water Company personnel upon request.

Spanaway Water Company hereby acknowledges cross connection control inspection of this vehicle. This permit is good for two years from the inspection date provided no plumbing changes in the vehicle have been made.

By: _____ Date: _____
Spanaway Water Company

By my signature I acknowledge that I have read and understand the terms of this agreement including approved cross connection control and the penalties associated with the unauthorized use of water;

Signed: _____

Position: _____

Date: _____

SPANAWAY WATER COMPANY, Inc.

18413 'B' Street East

Spanaway, Washington 98387-4619

(253) 531-9024

**CONSTRUCTION WATER USE AGREEMENT
ON-SITE FIRE HYDRANT METER USE AUTHORIZATION**

All on-site construction water will only be allowed under this agreement and contract with Spanaway Water Company (SWC). The unauthorized use of water will result in the following penalties;

- 1) First offense will result in a written warning
- 2) Second offense will result in \$500 fine and notification to Pierce County Sheriff department regarding theft of water
- 3) Third offense will result in \$1,000 fine, notification to Pierce County Sheriff department regarding theft of water; further use of water from Spanaway Water Company shall be prohibited.
- 4) Outstanding fines will prevent final water system approval and acceptance (new construction)

PARTY RECEIVING FIRE HYDRANT METER:

_____, as representative for:

Printed name of signer

Name of company

Company billing address

Company office address

City

State

Zip Code

(_____) _____

Phone number

Date: _____

Spanaway Water Company has provided one hydrant meter with gate valve –

Meter # _____

The hydrant meter will be only used on the following project;

The construction for which the hydrant meter is required is anticipated to be completed by
approximately this date _____

BACKFLOW PROTECTION:

All water trucks shall have approved cross connection control, preferably an approved air gap (please complete SWC 'Water Truck Authorization' form if using a tank truck or vessels). The contractor shall be responsible for all cross connection control.

- (a) At all times provide an installed State approved and successfully tested Reduced Pressure Backflow assembly (RPBA) or Double Check Valve Assembly (DCVA) before flowing any water.
- (b) All backflow assembly testing must be completed by a State Certified Backflow Assembly Tester (BAT). **A new test must be performed on the assembly for this specific project.** Passing test results must be provided to SWC prior to flowing any water. A copy of the test report shall be made available at the site for the duration of the hydrant meter use. (SWC can provide an updated BAT list. This list is provided as a courtesy to our water customers, it does not include all certified backflow assembly testers – only those who have provided SWC with their current certification information. The Spanaway Water Company makes no suggestion or recommendation regarding your selection of a contractor for testing or repair of backflow assemblies. Spanaway Water Company does not have control over fees and charges for backflow assembly testing or repair.)
- (c) All backflow protection installation must be inspected and approved by SWC personnel.

HYDRANT METER OPERATION:

The hydrant meter shall be attached directly to the hydrant's 2 1/2" port. Appropriate measures shall be taken to ensure the meter remains undamaged (support the weight of the equipment, protect from vandalism, freezing, improper use, etc.) Once approved cross connection control is in place the following operation procedures shall be used;

- (d) With the hydrant meter gate valve closed and DCVA connected, slowly fully open the hydrant.
- (e) The flow is to be controlled with the hydrant meter gate valve or hose nozzle, not the hydrant operating nut.
- (f) When use is not anticipated during the day and for all non-construction periods, including nights, the hydrant meter shall be removed from the hydrant and safely secured by the contractor. Whenever the meter is to be disconnected first shut off hydrant meter gate valve, then slowly fully close the hydrant. After removing the meter and DCVA from the hydrant check to insure the hydrant is draining and replace the port cap.

FIRE HYDRANT METER DEPOSIT:

A deposit of three thousand dollars (\$3,000.00) has been provided to Spanaway Water Company on behalf of the above named company as assurance of return of the referenced hydrant meter. **Said money will be deposited into a Spanaway Water Company account upon receipt.** The deposit, less water usage and rent fees, will be repaid to the above named company only upon return of the hydrant meter to Spanaway Water Company in undamaged condition. Repair fees for any portion of the hydrant meter and appurtenances, will be time and materials, up to and including full replacement cost. All repair fees will be withheld from the deposit.

DEPOSIT FORFEITURE NOTICE:

If at any time the party receiving the hydrant meter, or one of its sub-contractors, is found to be using water from a Spanaway Water Company source other than through the hydrant meter identified herein, all penalties for unauthorized use will apply. All deposits will be forfeited and consent to use the hydrant meter will be withdrawn. The deposit, less water usage and rent fees, will be repaid to the above named company only upon return of the hydrant meter to Spanaway Water Company in undamaged condition. Repair fees for any portion of the hydrant meter and appurtenances, will be time and materials, up to and including full replacement cost. All repair fees will be withheld from the deposit. Outstanding fines will prevent the project’s final water system approval and acceptance.

FIRE HYDRANT METER READING, RATES, AND USAGE BILLING:

The current meter reading as received is _____ cubic feet (cf). Water consumption will be billed at a rate of \$2.50 per 100 cf (100 cf of water is approximately 750 gallons). Monthly rent for the meter is \$175. Hydrant meters must be made available by the contractor for monthly reading by Spanaway Water Company. The hydrant meter is required to remain on the project site and will be made available at all times for reading upon request from SWC staff. Total payment for the fire hydrant meter will include water usage, the monthly meter rental fee, and any damage repair.

The meter reading as returned is _____ cubic feet (cf).

Amount billed for water use - \$ _____

Amount billed for rental fee - \$ _____

Amount billed for ‘time and materials’ repair fee - \$ _____

Total amount to be withheld from deposit - \$ _____

ACKNOWLEDGMENT AND SIGNATURE:

By my signature I acknowledge that I have read and understand the terms of this agreement including penalties for unauthorized use and issues that could result in deposit forfeiture.

Signed: _____

Position: _____

Date: _____

SPANAWAY WATER COMPANY, Inc.
POST OFFICE BOX 1000
SPANAWAY, WASHINGTON 98387-1000
(253) 531-9024

SAND BEDDING BOX USE AGREEMENT

All service connections shall have a 3-foot by 4-foot area of sand bedding. All projects shall use a 'sand bedding box' for all meter box bedding. Contractors may choose to fabricate and use their own 'sand bedding box'. A box will be available from Spanaway Water Company (SWC) if needed.

RECEIVING PARTY:

I, _____, as representative for:
(printed name of signer)

(name of company)

(company billing address)

_____) _____
(company office address)

(City) _____ (State) _____ (Zip Code)

(_____) _____ Date: _____
(phone number)

have received from SWC _____ 'sand bedding box' (boxes) to be used on the following project

The construction for which the 'sand bedding box' use is required is anticipated to be completed by approximately _____.

DEPOSIT:

A deposit of eight hundred dollars (\$800.00) per box has been provided to SWC on behalf of the above named company as assurance of return of the 'sand bedding box'. The deposit will be returned to the above named company only upon return of the box to SWC in undamaged condition. The cost for repair (if needed) and handling will be withheld by SWC from the deposit amount.

ACKNOWLEDGMENT AND SIGNATURE:

By my signature I acknowledge that I have read and understand the terms of this agreement including penalties for damages and possible forfeiture of the deposit.

Signed: _____

Position: _____

Date: _____

SPANAWAY WATER COMPANY

SERVICE AREA BOUNDARY 1 IN = 3,000 FT



PARKLAND
LIGHT & WATER

TACOMA
WATER DIVISION

WASHINGTON
WATER SERVICE

JOINT BASE
LEWIS MCCORD

24

23

22

21

25

26

27

28

29

35

34

33

2

3

